

## DOCUMENT RESUME

ED 455 090

SE 064 199

AUTHOR Butler, Malcolm B.  
TITLE Children's Literature with a Science Emphasis: Twenty Teacher-Developed K-8 Activity Packets.  
PUB DATE 2000-00-00  
NOTE 143p.  
PUB TYPE Guides - Classroom - Teacher (052)  
EDRS PRICE MF01/PC06 Plus Postage.  
DESCRIPTORS Aquariums; \*Childrens Literature; Conservation (Environment); \*Earth Science; Elementary Education; Environmental Education; Humidity; Hurricanes; \*Lesson Plans; Petrology; Physical Sciences; \*Science Activities; Scientific Literacy; Wind (Meteorology)  
IDENTIFIERS Earth; Moon; Seasons; Simple Machines

## ABSTRACT

This document features 10 science activity packets developed for elementary students by science teachers in a graduate seminar. The activity packets were designed to cover existing commercial children's books on specific content areas. The 10 activity packets are: (1) "Bringing the Rain to Kapiti Plain," which explains the water cycle; (2) "Hurricane City," which explains the different levels of hurricanes; (3) "Papa, Please Get the Moon for Me," which includes activities on the moon; (4) "The Seabreeze Hotel," which features activities about the wind; (5) "The Sleeping Porch," which includes activities on environmental changes; (6) "Welcome to the Sea of Sand," which features lesson plans on deserts and their habitats; (7) "Tops and Bottoms," which concerns plant growth, problem solving, and decision making; (8) "Verdi," which includes activities on animal life cycles and the ecosystem; (9) "Spring Snowman," which features activities on the states of matter and seasons; and (10) "Water Dance," which includes activities describing the forms of water. (YDS)

## Children's Literature with a Science Emphasis: Ten Teacher-developed K-8 Activity Packets

The 21<sup>st</sup> century is upon us. The need to better prepare our children to handle its challenges is apparent. The science knowledge and skills necessary to function as solid citizens are being discussed and debated at a fevered pitch. Whatever shape the "conversations" take, we realize that to excel as a country we must take advantage of our human resources. Teachers are acutely aware of these concerns, and are taking steps to improve the performance and attitudes of our children in science.

It is in the spirit of the excellent resources developed by Carol and James Butzow (1999, 1998, 1994, 1989) that this set of Activity Packets was designed. During the 1999 Spring semester, nine graduate students at various stages of their teaching careers came together in a professional seminar to design instructional materials that could help them teach children both literature and science. The culminating activity for the students was a group presentation at a regional reading conference. As a result of the positive response from conference participants, the students were encouraged and motivated to share their ideas with an even wider audience. What you see here is a sample of the fruition of their labors, with the Activity Packets left in their original forms to maintain the integrity of the students' unique ideas and writing styles.

The tradebooks included in this document are original in the sense that the Activity Packets were designed with the specific content areas covered in them in mind. The format of the packets is consistent with that used by the Butzows. A bibliography of similar books is included. The ten tradebooks highlighted here have been sorted according to the primary scientific category discussed— life, earth or earth/space.

It is hoped that this set of Activity Packets will be a welcomed addition to the educational resources available to those who are involved in improving the scientific literacy of our children. Most of all, we hope you enjoy using them, because we had a great time putting them together!!!

Malcolm B. Butler, Ph.D.  
The University of Georgia  
(This project was completed while Dr. Butler was a professor at Texas A&M University-Corpus Christi)

U.S. DEPARTMENT OF EDUCATION  
Office of Educational Research and Improvement  
EDUCATIONAL RESOURCES INFORMATION  
CENTER (ERIC)

- This document has been reproduced as received from the person or organization originating it.
- Minor changes have been made to improve reproduction quality.

- Points of view or opinions stated in this document do not necessarily represent official OERI position or policy.

PERMISSION TO REPRODUCE AND  
DISSEMINATE THIS MATERIAL HAS  
BEEN GRANTED BY

M. Butler

TO THE EDUCATIONAL RESOURCES  
INFORMATION CENTER (ERIC)

## **Children's Literature with a Science Emphasis: Ten Teacher-developed K-8 Activity Packets**

Listed below are the tradebooks highlighted in the ten Activity Packets, according to the three primary areas of science:

### **Earth/Space Science**

*Bringing the Rain to Kapiti Plain*

*Hurricane City*

*Papa, Please Get the Moon for Me*

*The Seabreeze Hotel*

*The Sleeping Porch*

*Welcome to the Sea of Sand*

### **Life Science**

*Tops and Bottoms*

*Verdi*

### **Physical Science**

*Spring Snowman*

*Water Dance*

# Children's Literature with a Science Emphasis: Ten Teacher-developed K-8 Activity Packets

## Bibliography of Related Resources

- Brainard, A., & Wrubel, D.H. (1994). *Literature-based science activities*. New York: Scholastic.
- Butzow, C.M. & Butzow, J.W. (1999). *Exploring the environment through children's literature: An integrated approach*. Englewood, CO: Teacher Ideas Press.
- Butzow, C.M. & Butzow, J.W. (1998). *More science through children's literature: An integrated approach*. Englewood, CO: Teacher Ideas Press.
- Butzow, C.M. & Butzow, J.W. (1994). *Intermediate science through children's literature: Over land and sea*. Englewood, CO: Teacher Ideas Press.
- Butzow, C.M. & Butzow, J.W. (1989). *Science through children's literature: An integrated approach*. Englewood, CO: Teacher Ideas Press.
- Cerullo, M.M. (1997). *Reading the environment: Children's literature in the science classroom*. Portsmouth, NH: Heinemann.
- Fredericks, A.D. (1998). *Science adventures with children's literature: A thematic approach*. Englewood, CO: Teacher Ideas Press.
- Gertz, S.E., Portman, D.J., & Sarquis, M. (1996). *Teaching physical science through children's literature: 20 complete lessons for elementary grades*. Middletown, OH: Terrific Science Press.
- Gork, M. (1995). *Literature-based science experiences for young children: Integrated thematic units to develop beginning skills*. New York: Incentive Publishers.
- Hefner, C.R. (1996). *Literature-based science: Children's books and activities to enrich the k-5 curriculum*. Phoenix, AZ: Oryx Press.
- Lipke, B. (1996). *Figures, facts and tables: Telling tales in science and math*. Portsmouth, NH: Heinemann.
- Osborne, R. & Freyberg, P. (1985). *Learning in science: The implication of children's science*. Portsmouth, NH: Heinemann.
- Scott, J. (1992). *Science and language links*. Portsmouth, NH: Heinemann.
- Shaw, D.G., & Dybdahl, C.S. (1996). *Integrating science and language arts: A sourcebook for k-6 teachers*. Needham Heights, MA: Allyn & Bacon.
- Staton, H.N., & McCarthy, T. (1994). *Science and stories: Integrating science and literature*. Glenview, IL: GoodYearBooks.

# **The Water Cycle**

## **Bringing the Rain to Kapiti Plain**

**a Nandi Tale retold by Verna Aardema**

**by: Tina Ybarra**

## **The Water Cycle**

**\*\*Bringing the Rain to Kapiti Plain\*\***

**A Nandi Tale retold by Verna Aardema**

**New York: Dial Books for Young Readers, 1981**

### **Background of story:**

This tale was discovered in Kenya, Africa, more than seventy years ago by the famous anthropologist Sir Claud Hollis. Sir Claud camped near a Nandi village and learned the native language from two young boys. He learned riddles and proverbs from the Nandi children, and most of the folktales from the Chief Medicine Man. This tale reminded Sir Claud of a cumulative nursery rhyme he had loved as a boy in England, one also familiar to us - "The House that Jack Built." So he called the story "The Nandi House That Jack Built" and included it in his book *The Nandi: Their Language and Folklore*, published in 1909. Verna Aardema has brought the original story closer to the English nursery rhyme by putting in a cumulative refrain and giving the tale the rhythm of "The House That Jack Built."

### **Summary:**

The Kapiti Plain was in dire need of the African rains. The relationship of the plants, animals and herdsman intermingle as the need for the rain becomes a necessity. Through the ingenuity of Ki-pat the "big, black cloud all heavy with rain" finally was pierced with an arrow and eagle feather and brought the rain to Kapiti Plain.

## **Science and Content Related Concepts:**

Water cycle, environment, balance of nature, migration, interdependence, animal instincts, survival, weather, clouds, thunder storms

## **Content Related Words:**

Kapiti Plain, Africa, sea of grass, drought, giraffes, eagle, cows, stork, thunder, cloud, weather, pasture, migrated, herdsmen

## **TEKS:**

1.2, 1.3, 1.7, 1.9, 1.10

2.2, 2.3, 2.5, 2.7, 2.9, 2.10

3.2, 3.3, 3.5, 3.8, 3.9, 3.11

4.2, 4.3, 4.5, 4.8, 4.9, 4.10, 4.11

5.2, 5.5, 5.6, 5.10, 5.11

## **Activities:**

1. On a map of the world, have students located Africa. Discuss the bodies of water surrounding Africa. Discuss the various landforms found in Africa.

2. You can make your own water cycle:

1. Put two teaspoons of water in a small plastic bag.
2. Blow air in and seal the bag with a heavy rubber band.
3. Place the bag in a sunny window.

The sun provides the energy to make the water cycle work.

3. The Rain Game (lesson plan attached) This game simulates the precipitation process.

4. Students can construct different types of clouds by cutting two sheets of construction paper simultaneously and stapling them part of the way together. Then they can be filled with newspaper or colored construction paper (white for snow, gray for rain, etc.) and decorated.
5. Students can write weather reports and share them with class.
6. Haiku poems (Japanese poems about nature) can be written to share with class. Students can also write poems about clouds or stories from a clouds point of view, discussing what type of cloud it is and what kind of weather it would bring.
7. Lesson: Condensation (attached).
8. Home-made clouds - to demonstrate the concept of precipitation (attached).
9. The water cycle song (to the tune of Are you Sleeping?) is used to teach the terminology of the water cycle with hand movements.
10. Moving Raindrops activity (attached).
11. Students can sequence and illustrate the story in a flip book as a precursor to the sequencing of the water cycle.
12. Water experiments can be easily incorporated through this lesson. Students can write about the results of these activities. You may want to make a class list of all the ways you can save water.
  - a. If there is a leaky faucet in your home, put a container (a cup or glass) under it to catch the drip. Leave the container under the faucet all night. Measure the amount of water collected overnight. Use this water to wash your hands or to water plants.



- b. Use a clock or watch with a minute hand for this experiment. Get a container and put it under the faucet. Turn the faucet on and let it run for one minute. Catch the water that runs into the container and measure the amount that ran in one minute. How can you reduce the amount of water you allow to run every day?
- c. Which uses more water - a shower or a tub bath? To find out, plug the drain of the tub and take a shower for five minutes. Then measure the water level in the tub with a ruler. Write it down. At another time, run water for a tub bath and take a bath. Measure the amount of water you ran for the bath. Which one used the most water.
- d. How much water do you use when you let the water run from the faucet until it is cool to drink? To experiment with this, put a pan in the kitchen sink under the faucet. Let the water run until it is cool. Then turn the water off. Pour the water in a measuring cup. How much is there? Use this water to wash your hands or water plants. How can you save the water that is usually wasted? Why is it important to save water? You might like to read this book: Know How to Make the World a Better Place by Jeffrey Hollender.
13. Discuss Bringing the Rain to Kapiti Plain as a folktale. What kind of history and values does this story reflect? You may want to locate and share other African folktales. Discuss the characteristics African folktales share with each other and with other folktales the children know.

14. Students can make a model of the Kapiti Plain to compare with their own setting. The characters and animals can be modeled from modeling dough made from this recipe.

3 cups flour

$\frac{3}{4}$  cups salt

1 teaspoon alum

1  $\frac{1}{4}$  cup hot water

Mix all the ingredients in a bowl. Knead for ten minutes. Model as you would with clay. Air dry or bake in an oven at 300 degrees until dry. Paint with tempera when dry. Materials can be glued to this model also.

### **Related Books and References:**

Aardema, Verna. Bringing the rain to kapiti plain. New York: Dial books for young readers, 1983.

Aardema, Verna. Why mosquitoes buzz in people's ears. New York: Scholastic.

Aardema, Verma. Princess gorilla and a new kind of water. New York: Dial books for young readers.

Arkhurst, Joyce C. The adventures of spider - west african folktales. New York: Little brown and company.

Chocolate, Deborah M. Spider and the sky god, an aran legend. Troll Associates.

Stanley, Diane and Vennema, Peter. Shaka - king of the zulus. New York: Mulberry paperbacks.

de Paola, Tomie. The cloud book. Orlando: Harcourt brace & company.

# The Water Cycle

Tiny drops of water gather together and make clouds. When clouds have more water than the air can hold up, the water falls to Earth as rain or snow.



## Water Travels

The water on Earth travels on an endless **cycle**, or journey. There are three steps to the water cycle: evaporation, condensation, and precipitation. Write the steps where they belong in the picture.

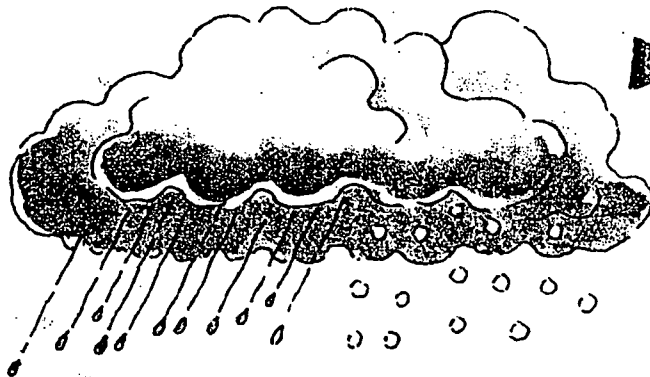

Rain and snow fall from clouds.



### WORD WATCH

Meteorology is the science of weather. Weather scientists are called **meteorologists**.

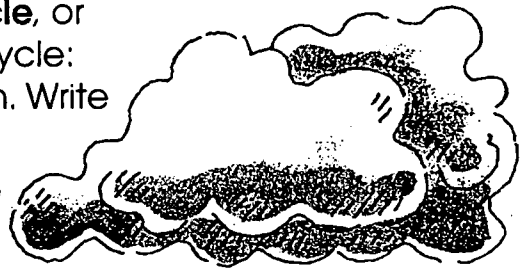

Water vapor makes a cloud.

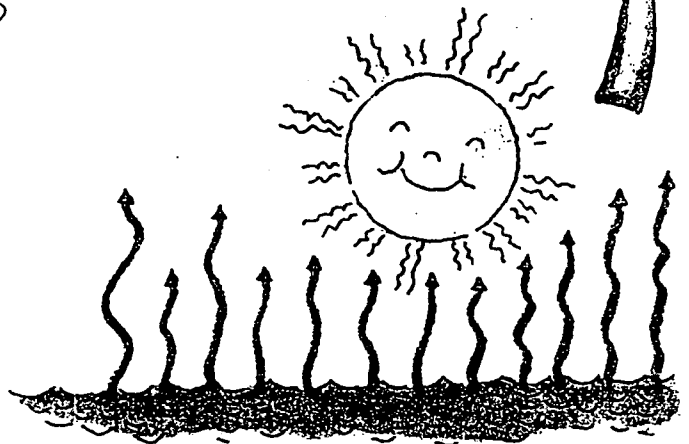

Heat from the sun changes water into water vapor.

Schmid, Eleonore. The water's journey. New York: North-south books.

Claire, Elizabeth. The sun, the wind and tashira. New York: Mondo publishing.

# Lesson: The Rain Game

## Prerequisites:

- Precipitation

## Objectives:

Simulate the precipitation process with the following activity.

## Materials:

- Assorted colored construction paper
- Rope or hula hoop

## Introduction:

none

## Body:

**Preparation:** Teacher should tape assorted pieces of construction paper in a random pattern on the ground outside or in a large room. Tape as many pieces of paper as there are students in the class.

**Game:** Outside or in a room with plenty of space, have the students find a piece of construction paper and stand on it with their arms outstretched. Tell them they are going to pretend they are a small cloud drop being blown about by the wind. When you say "go", have the students move from their piece of paper to another of the same color, keeping their arms spread out to their sides.

Each time one student touches another, they should grab hands as if they were becoming a larger cloud drop and continue moving on to a piece of paper which has the same color as the one from which they came. If students from two different colors should happen to collide en route, they should combine and move to the closest piece of colored paper. This will be the group's new color. Larger drops move about intermixed with smaller drops and keep combining in a similar manner. When a drop has five students in it, they have formed a raindrop and they should go to the puddle area and sit down. The puddle area is defined by a roped off area or hula hoop, located out of bounds. If drops combine to make a single drop of six or more students then it should divide in half, choose new colors, and remain moving throughout the cloud. Continue this game until the cloud is rained out and the puddle is full.

## Vocabulary Words:

none

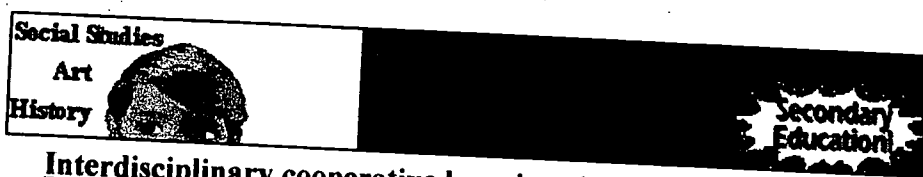

[Interdisciplinary cooperative learning simulations - click here!](#)

Teachers.Net Lesson Exchange

## #14. Home-Made Clouds

Science, level: elementary

Posted by Kyle Yamnitz ([kyle@coe.missouri.edu](mailto:kyle@coe.missouri.edu)).

The Lesson Plans Page

University of Missouri, USA

Materials Required: 1 large jar, 1 plastic bag of ice to fit over jar, a pitcher of warm water, 1 sheet of black paper, matches, and a flashlight

Activity Time: 1 class period

Concepts Taught: Cloud Formation

Topic: Cloud Formation Grade Level: Fourth

Concept: Cloud formation results when warm, humid air rises and cools, causing the water vapor in the air to condense and form clouds.

Teacher Materials: Student Materials:

--a large jar --pen and paper to record

--a plastic bag of ice that will fit observations over the jar opening

--a pitcher of warm water Optional Extension Student Materials:

--1 sheet of black paper --more jars, bags of ice, black paper

--flashlight flashlights, and warm water

--matches --collected dust

--flour

--sand

--cedar shavings

--any other particulate materials

--white construction paper

--newspaper

--crayons

Teacher Background Information:

Sunlight causes water to evaporate into the atmosphere. This air containing the water vapor is heated at the surface of the earth and rises. As it rises, it cools and the water vapor condenses on some form of particulate matter such as dust, ash, or smoke to form clouds.

**Management Strategies:**

This activity would be most appropriately done with small groups so that all students can view the cloud formation in the jar. Other class members could be working on researching the different types of clouds, drawing and labeling these clouds, researching and drawing the water cycle, working on a forecast for the rest of the day based on the clouds in the sky, etc. The activity itself should not take more than 10 to 15 minutes. For safety reasons, students should not be allowed to handle the matches. Also, students need to be careful around the glass jars. Much of the following procedure will vary, depending on students's reactions, comments, and levels of understanding.

**Procedure:**

1. Ask students what some of the different types of clouds are, what they are made of, and ask the focus question, how do you think clouds form? The responses to this question could be written on the board to return to later.
2. Tell the students that we are going to perform a simulation of the forming of a cloud. Take out the jar and have one of the students tape the black piece of paper onto one side of the jar. Ask another student to pour the warm water into the jar until it is one third full.
3. Light a match and hold it in the jar for a few seconds and then drop it in. At this point, have a student quickly cover the jar with the bag of ice.
4. Have another student (or teacher) shine the flashlight on the jar while they record their observations.
5. Now the students will explore what happened. The following questions can be used to help the class learn about what was happening:
  - What did you see in the jar? (a cloud)
  - Where did the cloud come from? (the water in the bottom of the jar)
  - How did the warm water effect the cloud formation? (caused the water to evaporate and warmed the air, causing it to rise)
  - What did the ice cubes do to help the clouds form? (cooled the air [made the water vapor condense]).
  - What role did the match and its smoke play in the cloud formation? (gave the water something to condense or grab on to)
  - Now what would you tell me a cloud is made of? (small water droplets)
  - Ask someone to describe the process of cloud formation from what they just learned.

**Assessment/Evaluation:**

As a learning activity in itself, assessment is not really needed, but an option for assessment would be to have students draw a picture of how the cloud formed in the jar. In addition, the products of the following extension activities could be assessed.

**Extension/Integration:**

As an application of what they learned, each student could draw a picture of how a real cloud would form, and what effects the warm earth and the cool air in the mountains would have. The process could be repeated by students without using the match or with dust, flour, sand, cedar shavings, or other particulate materials to see if the cloud would still form. As an art activity, students could construct different types of clouds by cutting two sheets of construction paper simultaneously and stapling them part of the way together. Then they can be filled with newspaper and decorated. For a math activity, students could record the clouds they see for a couple of weeks and graph how many days they saw each type of cloud. A language arts activity that could be used is to have students write weather reports and then present them to the class. Students could also write poems about clouds or stories from a cloud's point of view, discussing what type of cloud it is and what kind of weather it would bring.

**Source:**

Bugenig, D. (1996). How does a cloud form? [On-line]. Available: <ftp://ftp.unr.edu/pub/archive/mailling-lists/galileo/clouds>.

Source for the teacher background information and most of the extension activities was myself.

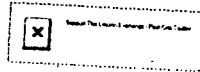

**[Submit Lesson](#) [Search](#) [Browse](#) [Request Lesson](#)**

[Home](#) | [Search](#) | [Reference Desk](#) | [Forum](#) | [Web Tools](#) | [Submit](#) | [Sponsor](#) | [Teacher Websites](#)

© 1997, Teachers.Net<sup>sm</sup>. All Rights Reserved.



# Lesson: Precipitation

## Prerequisites:

- The Water Cycle
- Condensation
- Evaporation

## Objectives:

1. To demonstrate the concept of precipitation

## Materials:

- Hot pot
- glass bowl with ice
- pie tin
- Water colors
- shiny paper
- "The Story of Rain"
- Red, yellow, blue, green, white construction paper

## Introduction:

1. Questions to stimulate thought:
  - What is rain?
  - How is rain made?
  - How are puddles formed?
  - What are clouds made of?

2. Read aloud : "The Story of Rain"

## Body:

Start some water boiling in a hot pot for use in section 2.

1. Students can sit at their desks while they do this section of the lesson. Pass out two sheets of shiny paper, a cup of water and a set of water colors to each student. First have the students get their brushes soaking wet and dip their brushes into the yellow paint. Have the students make many large yellow drops all over one sheet of the shiny paper. Rinse the brushes and make many large blue drops between the yellow drops being careful not to mix the drops. With a second sheet of shiny paper covering the desk, have the students lift their paper so that it is perpendicular to the desk and the drops start to run down the paper. The drops should slide down the paper and mix with each other dripping off the bottom of the paper as large green

drops. Ask: "What happened to the blue and yellow drops when you lifted your paper? What happened to the paper flat on your desk? Is there a new color on your papers? What is the color? How did the new color get there? Were the drops which fell off the bottom of your paper the same size as the blue and yellow drops?"

2. The class should gather around a common work place where they can all view the hot pot and bowl of ice. Explain to the class that you are going to hold the pot of ice water over the boiling water. Ask: "What do you think will happen - to the bowl of ice? to the steam? to the bottom of the bowl?" Once the water is boiling, hold the bowl of ice over the steam. Place a pie tin so that the water which drips from the bottom of the bowl will collect in the tin.

The class should observe and share what they observe happening. Some questions to help: "What do you see happening on the bottom of the bowl? What do you see happening in the pie tin? How does the water get on the bowl? Are the water drops on the side of the bowl the same size? Why? Which drops are falling from the bowl? Why? Which drops look like rain? Which drops look like a cloud? How are the big drops formed?"

Explain that the small misty drops which have condensed onto the side of the bowl of ice represent a cloud. The winds in a cloud blow the small drops around so that they collide with one another. During these collisions, some drops will combine with others making bigger and bigger drops. When the drops become so large that the winds cannot keep them in the sky, the drops fall as rain or precipitation. This is similar to the large drops falling from the bottom of the bowl.

## Conclusion:

Play "[The Rain Game](#)"

## Vocabulary Words:

- condensation
- precipitation

## Evaluation:

Defer evaluation until the end of the [Water Cycle](#) lesson.

## Followup Lessons:

- [The Water Cycle](#)

[About the Authors](#)

[Post Comments about the Unit](#)

[Read Comments about the Unit](#)

The rains come and the Kapiti Plain turns green again.

Ki-pat's cows are hungry because there is no grass.

Ki-pat makes arrows and shoots them into the dark rain cloud.

The Kapiti Plain is brown from no rain.

The Kapiti Plain is green from the rain.

# Lesson: Condensation

## Prerequisites:

- The Water Cycle
- Evaporation

## Objectives:

1. To demonstrate the concept of condensation

## Materials:

- Glass Cups or Jars
- Ice Cubes
- Water
- Paper Clips
- 8-10 Petri Dishes or similar shallow plates
- 4-5 tin lids
- Salt

## Introduction:

Questions to stimulate thought:

- What are clouds?
- How are they made?
- Have you ever seen a cloud close to the ground?
- What is that called? (fog)
- How is fog made?
- In the winter, when you walk outside, what happens to your breath when it hits the cold air?

## Body:

Divide the class into partners. Distribute a glass cup or jar to each group. Ask: "Do the cups feel wet or dry?"

Have the students fill their cups with ice. Add cold water to everyone's cup. Ask: "Do the cups feel wet or dry? Do the cups feel hot or cold?"

Let the cups sit for about one half hour. Ask: "What do you notice about the outside of your cups? Are they wet or dry? Where did the water come from? (teacher may need to direct the students towards the idea that the water came from the air.) Students can leave the ice water glasses out overnight or for several hours. If the class has studied evaporation, then discuss with them what happened to the water on the outside of the glass. If necessary refer to the evaporation lesson.

Now divide the class into four or five groups. Each group should get two petri dishes, two paper clips and one tin lid. Ask a member of each group to place the paper clips in one of the petri dishes, then set the tin lid on top of the paper clips. Have another group member give one shake of the salt shaker, or whatever it takes to get 6-10 salt crystals on the tin lid. Then the teacher will pour a thin layer of water into each petri dish so the tin lid doesn't get wet any water on it.

Now a member from each group should place an empty petri dish on top of each set up - careful to not bump any water onto the tin lid. (Could also use plastic wrap or some other clear cover.)

Let the set up sit for about one half hour. Ask for predictions from students of what they think might happen. Have one group member be a recorder and record what they see happening. (Eventually water from the dish will collect and condense around the salt crystals leaving little drops of salt water on the tin lid.) Ask: "What happened to the salt? Why are there drops on the lid instead of salt?"

Explain that the water evaporated from the dish and created air that had high humidity in the dish. Water from in the air collected around each salt crystal until the salt dissolved or melted. Now, all that is left are small drops of salty water on the tin lid. This process is called condensation. This is the same thing that happens in clouds before it rains. (Students may ask where the salt comes from or how does the salt get into the sky.) Explain that condensation can happen around other small particles like dust and that salt can get in the sky from the evaporation of ocean spray.

Each group can now take the lid off their set up and make predictions about what they think might happen to the drops. (After about half an hour, the water will evaporate and only salt will be left.) Ask the students to observe what they see on their lid. (They can taste it to discover that it is salt that is left.

If the class has already studied evaporation, then review what happened to the water. If they haven't, then this may make a great introduction.

## Conclusion:

Review with the whole group everything that has been studied in this lesson. Review with the class the process of evaporation - remind them of the puddle/plate experiment. Ask the class: "When water is evaporating where does it go? What happened to our cold glasses? Where did the water come from? What did we call the process where water comes from the air and collects into liquid? (condensation) What is the opposite of condensation, when liquid water goes into the air? (evaporation)"

## Vocabulary Words:

- condensation
- evaporation

## Evaluation:

Defer evaluation until the end of the Water Cycle lesson.

# The Water Cycle

Listen as your teacher explains the water cycle.  
Follow your teacher's directions for coloring and  
labeling the picture. Use words from the Word Box.

## Word Box

evaporation   precipitation   condensation

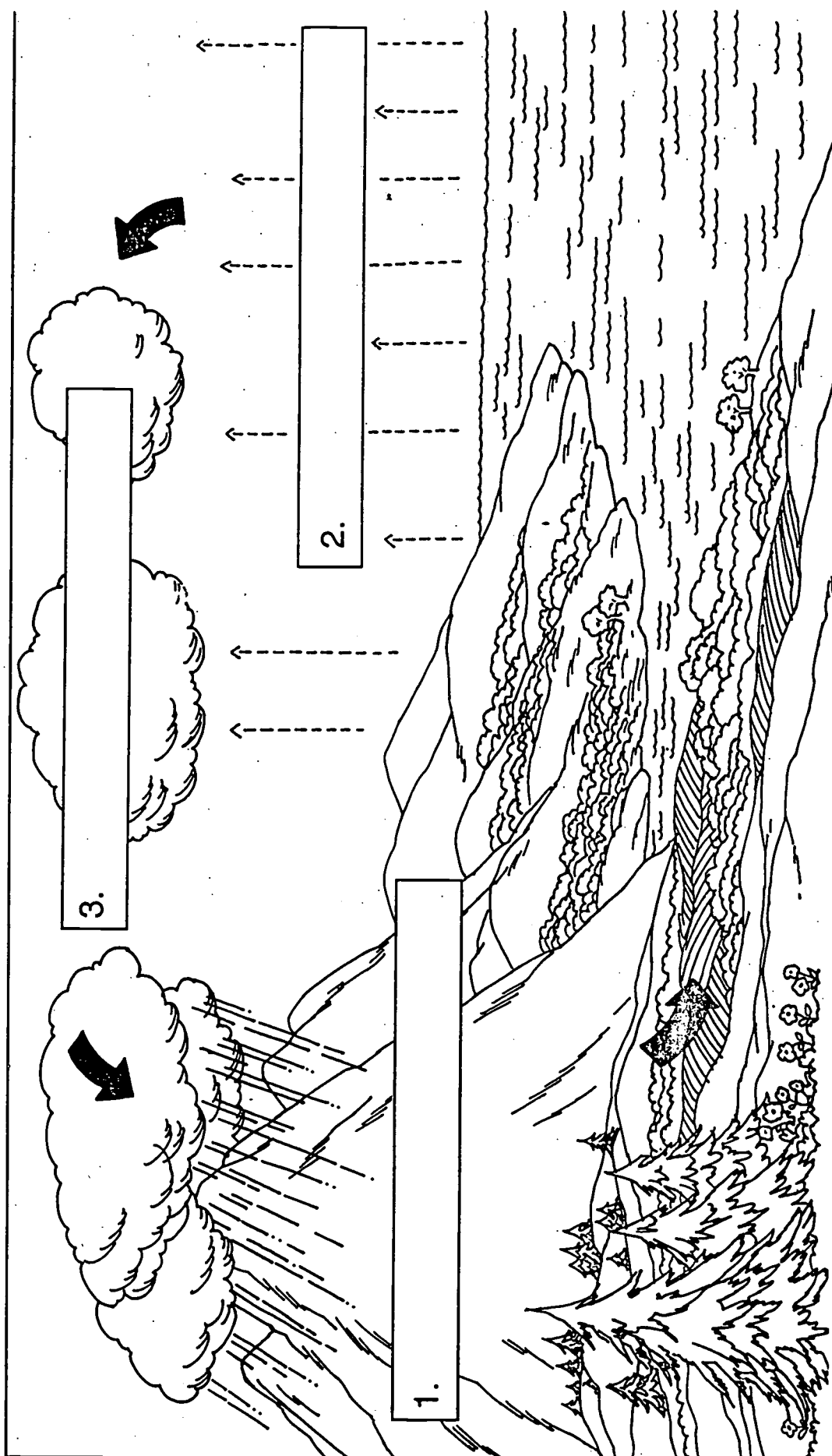

# Moving Raindrops

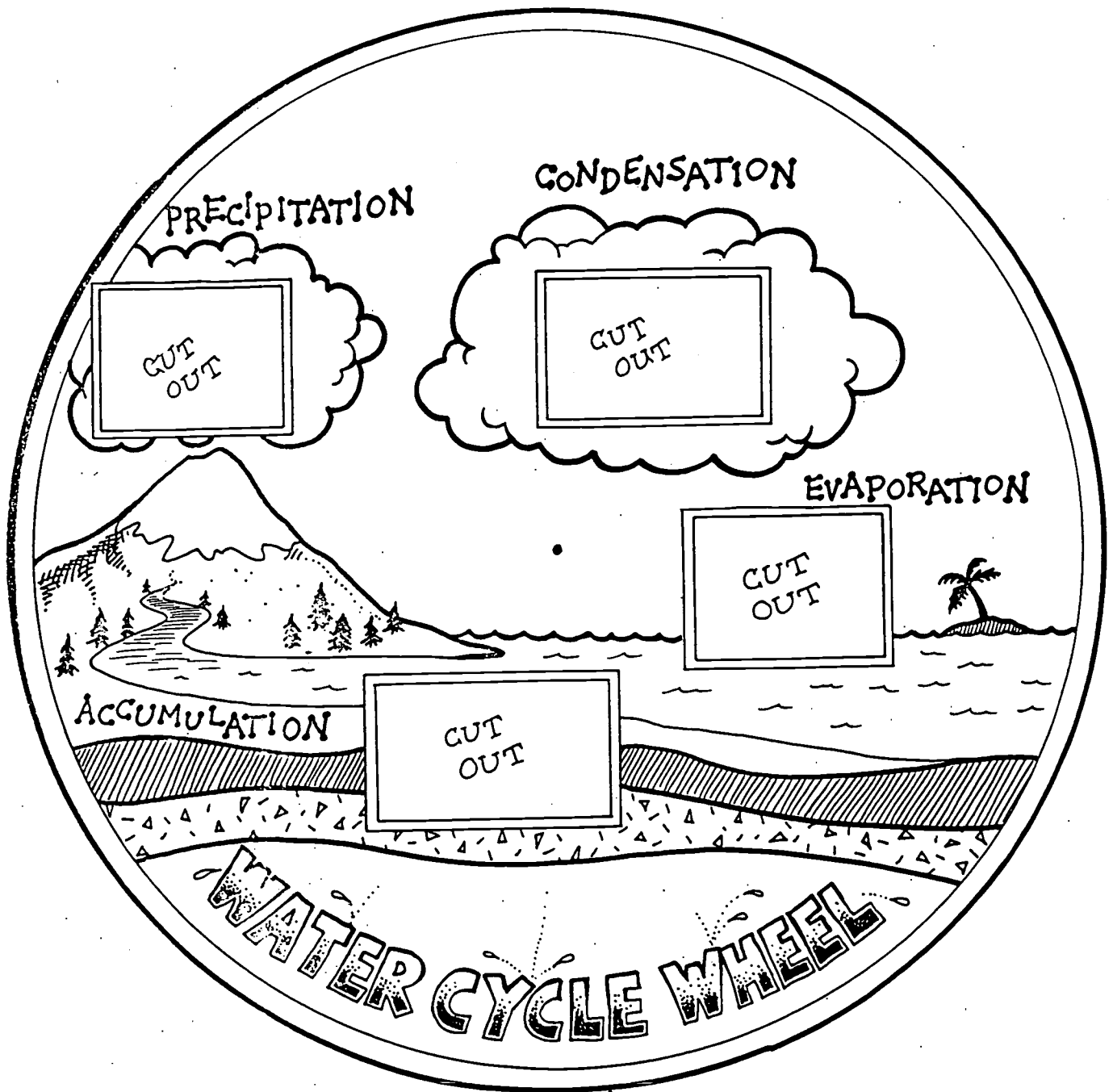

# Moving Raindrops

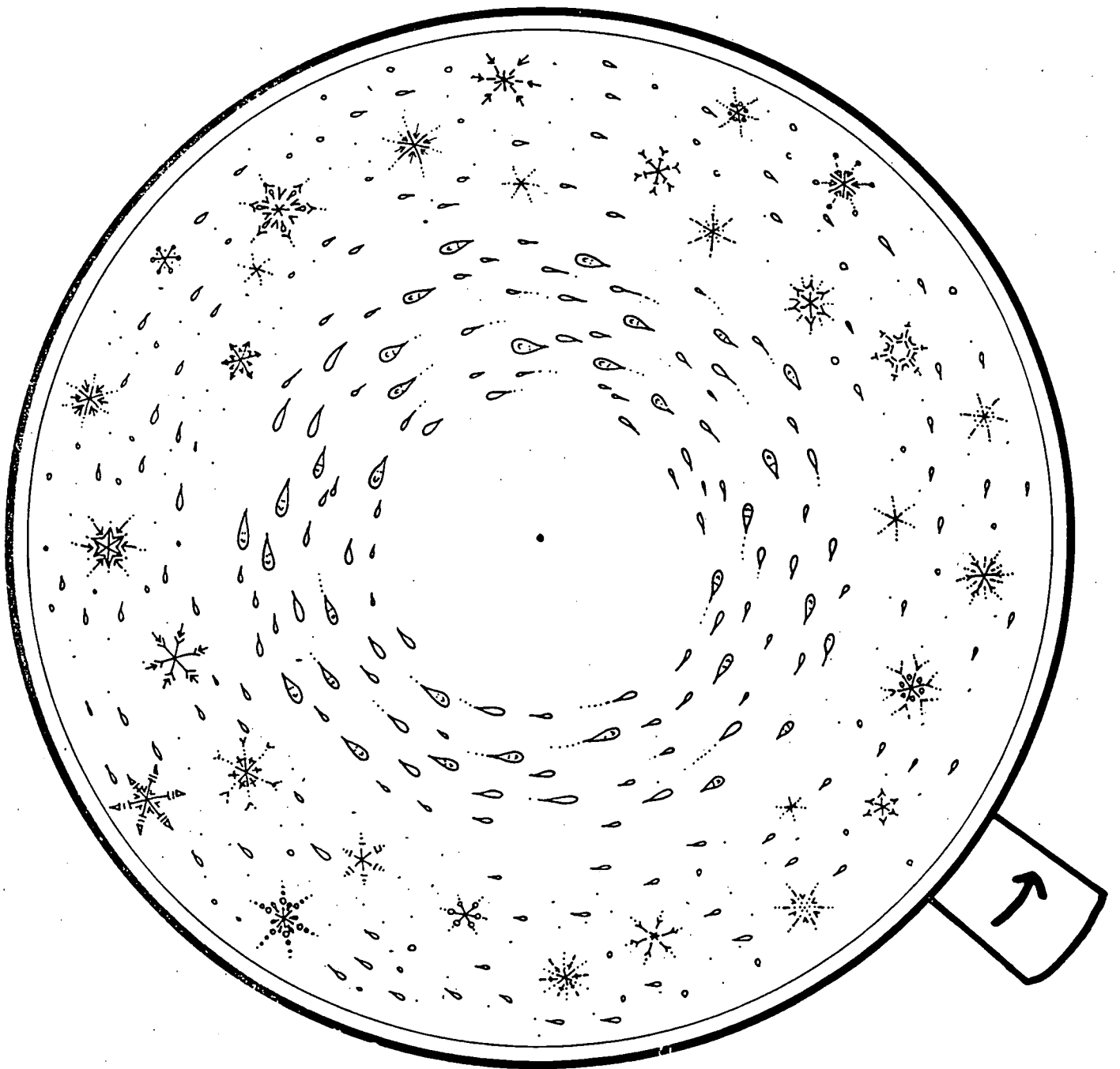



# Water Cycle Song

tune: Are You Sleeping?

Water cycle, water cycle  
All around, this we've found.  
Here is how to do it:  
Water moves on through it,  
Here and gone, moving on.

From the ocean, lakes and puddles,  
To the air, everywhere.  
Rain or snowy weather  
Bring it down together  
To the ground, 'round and 'round.

Evaporation, evaporation;  
Condensation, condensation;  
Precipitation, precipitation;  
Accumulation, accumulation.

## **Hurricanes**

### **Hurricane City**

By Sarah Weeks

Harper Collins, 1993

*Caroline Weber*

#### **Summary:**

A family, which lives in Hurricane City, describes different types of hurricanes. The story travels through the alphabet as well as the repercussions of hurricanes.

#### **Science and Content Related Concepts:**

Different levels of hurricanes, alphabet, weather

#### **TEKS:**

Kindergarten: K.2, K.4, K.5, K.7, K.9

Grade 1: 1.2, 1.3, 1.5, 1.7, 1.9

Grade 2: 2.2, 2.3, 2.5, 2.7, 2.9

#### **Activities:**

1. After discussing hurricane warnings have the students create their own hurricane warning and hurricane flags. The hurricane warning flag is plain red, the hurricane flag is red with a black square in the middle. The students can create these from construction paper, poster board, or cloth.

2. Have a meteorologist from a local television station come talk to the students about hurricanes. He can speak about prediction, weather instruments, tracking, hurricane aftermath, etc.
3. Have the students track a hurricane. For the younger students, the teacher will have to plot the hurricane and help the students follow it. Older students may be able to plot the coordinates themselves. Have the students discuss the pattern of the hurricane.
4. Discuss the impact of the wind during a hurricane. Talk about the different things that may be affected by the wind. Next, give the students straws and have them feel the “wind” as they blow through the straw. Give the students cotton balls and have them blow them across the table with the straws.
5. In order to demonstrate the force of the waves and the roll the wind plays in creating those waves fill a pan with water and have the students blow on it with a straw. The students will be able to see the different size waves in the pan. Next, put toy boats in the water and have the students use the straws to move the boats. Do the boats tip over if you blow hard?
6. Discuss the different ways to prepare for a hurricane. Have the students(in small groups) consult a food pyramid and decide which foods they would need to have on hand if a hurricane hit. Each list must contain foods from each group. The students will then share and compare their lists with the class.
7. Have a discussion on things that wash up on the beach after a hurricane. Discuss how things, such as shells, wash up from far off places. Have the students think of different

things that might land on the beach. Also, talk to the students about all of the trash that washes up after hurricanes.

8. Turn on a small oscillating fan. Sprinkle a small amount of baby powder above the fan. The students will be able to see the wind as the fan blows the powder. Next, blow bubbles in front of the fan. Have the students predict what will happen.
9. Go through the letters of the alphabet and have the students pick a hurricane name for each letter. Have the students describe or draw the effects of this hurricane. Have them describe the destruction of their hurricane and why.
10. Have a discussion on hurricane safety. How would they protect their house, boat, pet, family, etc. Discuss shelters and community involvement. Review the hurricane flags, food preparation, and other lessons from the week. Have a safety drill in your classroom.

## Related Books and References

Erlbach, Arlene. Hurricanes. Childrens Press: Chicago. 1993.

Lampton, Christopher. Hurricane. The Millbrook Press: Brookfield, CT. 1991.

Greenberg, Keith Elliot. Storm Chaser. Blackbirch Press: Woodbridge, CT. 1998.

Simon, Seymour. Storms. Morrow Junior Books: New York. 1989.

Wiesner, David. Hurricane. Clarion Books: New York. 1990.

Finkel, Susan; Seberg, Karen. Circle Time- Science. Teaching and Learning Company:  
Carthage, IL. 1996.

Herr, Judy; Libby, Yvonne. Creative Resources for the Early Childhood Classroom.  
Delmar Publishers Inc: New York. 1995.

Suzanna Felts  
EDCI 5390

Title of Book: *Papa, please get the moon for me*

Author: Eric Carle

Science Concepts/Facts in the Book: moon, moon phases, outer space

TEKS: 4.6, 4.10, 5.6, 5.12

Science Vocabulary: phases, new, waxing crescent, first quarter, waxing gibbous, full, waning gibbous, last quarter, waning crescent, craters, reflect

Possible Activities/Science:

1. Give each group of students a phase of the moon to research: new, waxing crescent, first quarter, waxing gibbous, full, waning gibbous, last quarter, waning crescent. After researching, have each group prepare a poster-size drawing and a report of the phase they researched.
2. Does the moon shine?
  - a. Discuss the meaning of reflecting and self-emitting.
  - b. Place an object on a table in a darkened room without students noticing. Ask "What is on the table?" When no one can answer, ask "What do you need to be able to see the object?" when the correct answer is given turn on the lights. Discuss why the object can be seen now. Elicit statements that the object reflects light but does not give off light.
  - c. Turn off the lights again. Have students look at the lights and ask if they can see them. Turn the lights back on and ask if they see the lights now. Discuss how some objects emit their own light and other objects reflect light.
  - d. Discuss the meaning of hypothesis. Have students predict an answer to the question "What causes the moon to give off light?" Explain that a demonstration can prove or disprove their predictions.
  - e. Hang a 1-inch diameter ball on a 1-inch length of string from the inside of the lid of the box so it hangs down near one end of the box. The ball represents the moon.
  - f. On the opposite end of the box, cut a circle the size of the flashlight, fit it into the circle and seal the flashlight into place with tape. This represents the sun.

- g. Cut a small eye hole two inches directly under the flashlight.
- h. Put the lid on the box and have students explain what they see as they look through the eye hole with the flashlight turned off.
- i. Turn on the flashlight. Have them look through the eye hole and describe what they see. Ask "Do you see the ball because it gives off its own light, or because it reflects light?" "How do you know it's reflecting light?"
- j. Discuss the two kinds of light seen in the box: direct light given off by the flashlight and reflected light from the ball.
- k. Suspend a 2-inch ball halfway between the first ball and the flashlight, hanging down about 4 inches from a string. This represents the Earth.
- l. Close the box lid, seal the eye hole and make a new one centered on the long side of the box.
- m. Turn on the flashlight and direct students to look at the ball representing the Earth. Ask "Can you tell which side is day and which is night?" "Which side would you be on if you could see the moon?" "Which side would you be on if you could see the sun?" "How could you see the moon if you are on the dark side of the Earth?"
- n. Have students state whether the moon gives off its own light or reflects it. Ask them to check if their original hypotheses were correct.

## 2. Lunar Lollipops

Materials: light bulb suspended from the ceiling or on a stand, a 2-3 inch styrofoam ball on the end of a pencil (one for each student), plenty of room for students to rotate in

- a. Turn on the model sun and turn off the other lights in the room. Have students stand. Tell them in this system the lamp is the sun and their head is the Earth. Their nose is their hometown on the surface of the Earth.
- b. Hand out the lunar lollipops (moons) and tell students that it should be held at arm's length away from their head. Demonstrate how the moon orbits the Earth in a counterclockwise fashion (from right to left). As students watch their moon they will see that it will go through phases similar to those of the real moon.
- c. Go through the 8 major phases of the moon with students:

\* New Moon—moon is between the sun and the Earth and they see the shadowed side of the moon. A solar eclipse occurs in this phase when the moon blocks light from the sun from reaching a portion of the earth. Students can close one eye and simulate this event.

\*Waxing Crescent—rotate one step to the left, rotating from a new moon toward a first quarter, backwards “c” shape will appear on the moon.

\*First Quarter—right half of the side of the moon facing earth is lit, the right shoulder is facing the sun.

\*Waxing Gibbous—take one step to the left, rotating from a first quarter to a full moon.

\*Full Moon—Earth is between the moon and the sun, the entire lit side of the moon is visible on Earth, students’ backs are to the sun and moons are lifted up to be lit. A lunar eclipse occurs when the moon passes through the Earth’s shadow. Have students simulate this event.

\*Waning Gibbous—take one step to the left, rotating from a full moon to a last quarter, less and less of the moon is lit each night.

\*Last Quarter—left half of the side of the moon facing the Earth is lit, left shoulder is pointing to the sun.

\*Waning Crescent—take one step to the left, rotating from a last quarter to a new moon, A “c” shape of light is seen on the left side of the moon.

d. Have students repeat the phases on their own as you circulate through the room to correct any problems.

e. Evaluate the lesson by naming a moon phase and having students rotate until they are in the correct phase. Jumble the phases to make it more of a challenge.

3. Discuss the Apollo missions to the moon. Show photographs of the lunar landing available from NASA or on the Internet.

4. Review facts about the moon through myth and reality cards.

#### Reality

a. The Earth’s moon is the fifth largest in the whole solar system.

b. The moon doesn’t produce it’s own light.

c. The moon phase changes as the moon orbits the Earth.

d. There are dark regions and light regions on the moon.

e. Pieces of rock rained down on the moon’s surface billions of years ago to create craters.

f. The moon has mountain ranges.

g. There is no wind on the moon.

h. Asteroid-like objects hit the moon billions of years ago.

i. Lava flowed and filled in basins on the moon.

j. When the moon appears smaller than a quarter, we call it a crescent.



- k. When the moon is getting smaller, it is waning.
- l. A lunar eclipse occurs when the moon passes through the earth's shadow.

### Myth

- a. The moon has atmosphere.
- b. The foot prints left behind by the Apollo astronauts have disappeared.
- c. The temperatures on the moon are very cold during the day.
- d. The moon is larger than the Earth.
- e. Light-colored areas on the moon have very few craters.
- f. Objects weigh more on the moon than on Earth.
- g. There are no blue moons.
- h. There is really a man in the moon.
- i. There was only one lunar landing.
- j. John Glenn was the first astronaut to walk on the moon.

### 5. The Creation of Craters

Materials: several bowls filled with 2 inches of flour

Bring students together and discuss the surface of the moon. Show pictures of the moon's surface and talk about the different features you might find on the moon (hills, craters, valleys and mountains). When the students have had a chance to discuss the different geographical formations, move into talking specifically about craters. Have the children brainstorm ideas about how craters were formed. Discuss with students that craters were created from rock hitting the moon's surface. Have students hypothesize about how different sizes, different speeds and different dropping heights or meteorites and how that would affect the size of the crater. Offer a demonstration. Take marbles and drop them from varying heights into the flour and have the children observe the holes and the differences and size. If they don't observe it point out how the distance that the marble has fallen affects the size and shape of the crater.

### 6. Moon Base Game

Materials: construction paper, scissors, tape, rulers, two large sheets of butcher paper with teacher-made circles identically drawn onto each piece, blackboard, chalk, 3" x 5" index cards or 3" x 5" cards made from construction paper

- a. Divide the class into two teams.
- b. Hand out construction paper and instruct each team to collectively construct and paint one spaceship for the entire team.
- c. Hand out butcher paper and have each team paint on the face of the moon, adding landmarks and place names. Assign point values to each landmark, as on a dartboard.

Extra points are gained if the spaceship hits one these spots.

- d. Brainstorm facts about space. Write the facts in the form of questions on one side of the cards and answers on the opposite side.
- e. Shuffle the cards. Have each team take a turn drawing a card, then attempting to answer the question posed on the card. If the answer is correct, the team will win a predetermined number of points for having the right answer. Keep score on the chalkboard. They will also win an opportunity to fly their spaceship to the moon.
- f. Place the moon on the floor 1 to 5 feet away from the launch pad (a taped line on the floor). The spaceship will be tossed to the moon. If the spaceship lands on a landmark, the team earns the number of extra points indicated.
- g. The team having the most points at the end of the class period wins.

#### Possible Activities/Language Arts

1. Discuss the following sayings about the moon.
  - a. Ask students to draw what they think a Blue Moon is. After students have drawn and shared their pictures, discuss that a blue moon is the name given to the second full moon in a calendar month.(information attached)
  - b. Ask students what they think the saying “once in a blue moon” means. This is a very old saying that means something does not happen very often.(information attached)
2. Discuss moon illusions with students. There are quite a few images you can see when looking At the full moon, depending on the season, the viewers location and the time of night. Show students pictures of the man in the moon (Eric Carle draws a face on the pictures in the book also), the lady reading a book, the rabbit, and St. George slaying the dragon. Have students write a story about how the picture of the man in the moon got there.
3. Compare how two phases of the moon are alike and different.
4. Write Haiku poems bout the moon. Haiku is Japanese poetry that is unrhymed and celebrates nature.

Line 1 — 5 syllables

Line 2 — 7 syllables

Line 3 — 5 syllables

#### 5. Word Ladder

- a. Sometimes you can see the face of the \_\_\_\_\_

- b. When there is a second full moon in a month, it is called a \_\_\_\_\_.
- c. The Earth \_\_\_\_\_ on it's axis in twenty-four hours, causing us to have night and day.
- d. The moon is \_\_\_\_\_ light from the sun.
- e. There are eight moon \_\_\_\_\_.
- f. Because we live on the \_\_\_\_\_ we are able to see the moon easily.
- g. The name given to the missions exploring the moon was \_\_\_\_\_.
- h. The \_\_\_\_\_ gives off light which is reflected by the moon.
- i. When rock hit the moon, it left many \_\_\_\_\_.
- j. The moon is part of the \_\_\_\_\_.

M \_\_\_\_\_

\_\_\_\_\_ O \_\_\_\_\_

\_\_\_\_\_ O \_\_\_\_\_

\_\_\_\_\_ N \_\_\_\_\_

P \_\_\_\_\_

\_\_\_\_\_ H \_\_\_\_\_

A \_\_\_\_\_

S \_\_\_\_\_

\_\_\_\_\_ E \_\_\_\_\_

S \_\_\_\_\_

### Words Used

sun  
earths

phases  
craters

rotates  
man in the moon

reflecting  
blue moon

Apollo  
solar system

### Possible Activities/The Arts

1. Activity 6 under Science incorporates Art.
2. Make a Moon Globe

Materials: one large round balloon, newspaper, liquid starch ( or dry starch mixed with water to the consistency of Elmer's glue) and maps or a globe of the moon.

- a. Inflate the balloon.
  - b. Tear the newspaper into long, narrow strips.
  - c. Dip the newspaper in the starch and lay the strips one at a time on top of the balloon. Each piece of newspaper should be placed perpendicular to the piece underneath it. The ends can overlap the underneath layers. Cover the whole balloon.
  - d. When the newspaper is six layers thick, start to build mountains and high places. To do this, make a wad of starched newspaper roughly the shape and size of the mountain, ridge, or high place. Place it on the moon globe in the proper spot and attach it by laying flat strips of starched newspaper over the wad. Press the ends of the strips against the flat, low spots to hold the mountains in place.
  - e. After the globe is modeled, let it dry. Then paint it with tempera or acrylic paint. Label The main landmarks, particularly the Sea of Tranquility where the Apollo 11 astronauts Neil Armstrong and Edwin E. Aldrin, Jr. landed on July 20, 1969.
3. Create songs about the phases of the moon or moon facts.
  4. Have students act out the landing on the moon.

### Possible Activities/Math

1. Have students create graphs using Lucky Charms cereal. Place students in groups and have them separate out all the parts of the cereal and then come with a total for all parts. Create bar graphs and pictographs of the information.
2. Provide students with the opportunity to understand fractions using the moon.

Materials: 3 drawings of the moon, pencil, ruler, red crayon, blue crayon, green crayon

- a. With the pencil, mark the center of each moon drawing. Draw a straight line through the mark from one edge to the other using a ruler. The moon drawing is now divided into 2 equal parts. Each part is  $\frac{1}{2}$  of the moon drawing. Some students parts may not be exactly equal if their mark was not exactly in the middle. On one moon drawing write  $\frac{1}{2}$  in each of the two parts. Shade in 1 part or  $\frac{1}{2}$  of the moon drawing using a red crayon.
- b. On a another moon drawing, draw a second line through the center mark so the drawing is divided into 4 equal parts. Each part is  $\frac{1}{4}$  of the moon drawing. Write  $\frac{1}{4}$  in each of the four parts. Shade in 1 part or  $\frac{1}{4}$  of the moon drawing using the red crayon
- c. On the third moon drawing, draw a second line through the center mark so the drawing is divided into 4 equal parts. Then draw two more lines through the center mark dividing the moon drawing into 8 equal parts. Each part is  $\frac{1}{8}$  of the moon drawing. Write  $\frac{1}{8}$  in each of the eight parts. Shade in 1 part or  $\frac{1}{8}$  of the moon drawing with the red crayon.
- d. Look at the three moon drawings. Which shaded part is the largest,  $\frac{1}{2}$ ,  $\frac{1}{4}$ , or  $\frac{1}{8}$ ? Which is the smallest? What happens to a fraction as the denominator, the bottom number, changes? As the denominator gets larger, the fraction gets smaller. As you divide the moon drawing into more and more pieces, each piece gets smaller and smaller.
- e. On the third drawing ( the one divided into eighths) shade in 2 sections using the green crayon. The sections should be next to each other. You have shaded in  $\frac{2}{8}$ . With the blue crayon shade in 3 sections. The sections should be next to each other. You have shaded in  $\frac{3}{8}$  of the moon drawing. It is clear that there's more moon shaded in the blue section than in the green section. And more in the green section than in the red section.  $\frac{3}{8}$  is more than  $\frac{2}{8}$  or  $\frac{1}{8}$ .  $\frac{2}{8}$  is more than  $\frac{1}{8}$ . What happens to a fraction as the numerator, the top number, gets larger? As the numerator gets larger the fraction gets larger.

# The Blue Moon

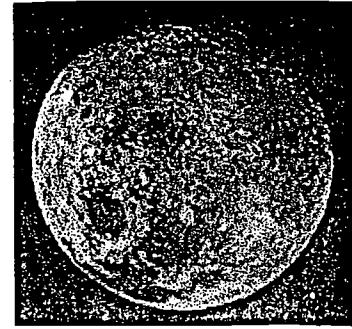

A "Blue Moon" is the name given to the second full moon in a calendar month. Because there are roughly 29.5 days between full moons, it is unusual for two full moons to "fit" into a 30 or 31 day month (and impossible to fit into a 28 or 29 day month, so February can never have a Blue Moon). The saying "Once in a Blue Moon" means a rare occurrence, and predates the current astronomical use of the term, which seems to be quite recent. In fact, Blue Moons are not all that rare, on average there will be one Blue Moon every 2.5 years. After 1999, the next Blue Moons will be in November 2001; July 2004; and June 2007. The last one before 1999 was in July 1996.

## The Double Blue Moon of 1999

In January and March of 1999, we have a situation which only takes place about four times a century: two Blue Moons occurring in the same year. The last time this happened was in January and April of 1961 and it will not happen again until January and March of 2018. A double Blue Moon most commonly occurs in January/March but is also possible in January/April or January/May and only when there is no full moon at all in February. It is also possible to have a Blue Moon in December of one year and March of the next year, again, there is no full moon in the intervening February. See the links below for more details.

Full Moons January-March 1999	
Eastern Standard Time	Universal Time (GMT)
January 1, 9:51 p.m.	January 2, 02:51
January 31, 11:08 a.m.	January 31, 16:08
March 2, 1:59 a.m.	March 2, 06:59
March 31, 5:49 p.m.	March 31, 22:49

- [☐ The Blue Moon Page - including a Blue Moon Calculator](#)
- [☐ Folklore of the Blue Moon - The origins of the term "Blue Moon"](#)
- [☐ Moon illumination for a given year - U.S. Naval Observatory](#)
- [☐ Moon phases for a given year](#)

- [☐ NSSDC Moon home page](#)
- [☐ NSSDC Moon fact sheet](#)
- [☐ Planetary home page](#)

*Questions and comments about this page should be addressed to:  
 Dr. David R. Williams, [dwilliam@nssdc.gsfc.nasa.gov](mailto:dwilliam@nssdc.gsfc.nasa.gov), (301) 286-1258  
 NSSDC, Mail Code 633, NASA/Goddard Space Flight Center, Greenbelt, MD 20771*

# Folklore of the "Blue Moon"

Philip Hiscock

MUN Folklore & Language Archive  
Memorial University of Newfoundland  
St John's, Newfoundland A1B 3X8  
Canada

Depending on where you lived, 1993 had a "blue moon" in either August or September. If you were east of a line running down the Atlantic Ocean, the blue moon fell in September; west of that line, the blue month was August.

There is a lot of folklore about the moon. Modern folklore has it that full moons make for better parties and higher booking rates at mental hospitals, but all the serious studies I've read deny the relationship.

The most interesting bit of modern folklore from my point of view as a student of language and folklore is the sudden popularity of the term "blue moon." Names of moons at certain times of the year have been around a long time, and almanacs are especially wont to list twelve of them. The Harvest Moon is the best known of these, lighting up the fields sometime after the fall equinox, enabling work to continue late into the night. Of course folklorists know that the traditional belief is widespread that certain crops harvested by the light of the moon, or alternatively in the waning of the moon, keep better than those cut at other times. The full Harvest Moon was a signal, to those who would listen, that it was time to start the last work of the year in the fields. The late fall Hunter's Moon was invented by analogy with the Harvest Moon, and some of the other almanac moon names have the same ring of later invention.

Blue Moon is different from the monthly or seasonal moon names as it isn't restricted to a time of year. It is a movable feast.

At least once during August or September this year [1993], you probably heard through the media about the "blue moon." People have been saying that "according to folklore" the second moon in a calendar month is a "blue moon." So, they say, this is the origin of the phrase "once in a blue moon." Don't believe them! "Once in a blue moon" is old, about 150 years old, but the two-full-moons-in-a-month meaning of "blue moon" is a lot younger than that. The older meaning may be wishy-washy and the newer one solid and technical, but don't let anyone tell you they have replaced one with the other.

It's not rare to see two full moons in a month. Because the moon and our calendar are not in sync and all the months but February are longer than the moon's synodical cycle, it happens about seven times in every nineteen years. That's every thirty-three months on average. Months have different lengths, so the phenomenon moves around a bit. In 1999 there will even be two "blue" moons. If you think about it, it's a little like getting paid every second Friday and finding that some months you get paid three times instead of twice.

Meaning is a slippery substance. The phrase "blue moon" has been around a long time, well over 400 years, but during that time its meaning has shifted. I have counted six different meanings which have been carried by the term, and at least four of them are still current today. That makes discussion of the

term a little complicated.

The earliest references to a blue moon are in a phrase remarkably like early references to the moon's "green cheese." Both phrases were used as examples of obvious absurdities about which there could be no argument. Four hundred years ago, if someone said, "He would argue the moon was blue," the average sixteenth century man would take it the way we understand, "He'd argue that black is white." This understanding of a blue moon being absurd (the first meaning) led eventually to a second meaning, that of "never." To say that something would happen when the moon turned blue was like saying that it would happen on Tib's Eve (at least before Tib got a day near Christmas assigned to her). Or that it would be on the Twelfth of Never.

But of course we all know there are examples of the moon actually turning blue; that's the third meaning--the moon visually appearing blue. When the Indonesian volcano Krakatoa exploded in 1883, its dust turned sunsets green and the moon blue all around the world for the best part of two years. In 1927 a late monsoon in India set up conditions for a blue moon. And the moon here in Newfoundland was turned blue in 1951 when huge forest fires in Alberta threw smoke particles up into the sky. Even by the mid-nineteenth century it was clear that although visually blue moons were rare, they did happen from time to time. So the phrase "once in a blue moon" came about. It meant then exactly what it means today--that an event was fairly infrequent, but not quite regular enough to pinpoint. That's meaning number four, and today it is still the main one.

I know of six songs which use "blue moon" as a symbol of sadness and loneliness. In half of them the poor crooner's moon turns to gold when he gets his love at the end of the song. That's meaning number five: check your old Elvis Presley or Bill Monroe records for more information.

Finally, in the 1980s, came the most recent meaning of blue moon--the second full moon in a month. I first became aware of the new meaning of the term in late May, 1988, when it seemed that all the radio stations and newspapers were carrying an item on this interesting bit of "old folklore." At the MUN Folklore & Language Archive we get calls from all over, from people wondering about bits of folklore, and in that month I got calls about blue moons. You see there were two full moons that month.

There have been just a few double moon months since then, and this year--1993--was peculiar because the "blue moon" fell in either August or September. It fell in different months depending on where you live because the full moon was so close to midnight on the night of August 31st-September 1st. Some places got it before local midnight; others after. If your local full moon was before your local midnight, then your blue month was August; and if it fell after midnight, your blue month was September.

Back in 1988 I searched high and low for a reference to the term having this meaning, or for any other term used to describe two moons in a single calendar month. But it was in vain. There seemed to be just no history to this term. I uncovered information on the other meanings of "blue moon." But not this blue moon, meaning number six.

In December 1990, with a new "blue moon" coming on, I started getting calls again and I searched harder this time. I had already exhausted all the usual sources of historical and astronomical dictionaries, indexes of proverbial sayings and the like. A brand new edition of the huge Oxford English Dictionary had come out in the meantime, but even that seemed to have nothing on this new usage. A new tack was called for.



Almost every day I use computer networks to contact other folklorists around the world, so I started with them. But no one could give me a use of the term earlier than the 1988 wire stories. I then turned to other computer networks, for scientists and especially astronomers. Still no luck. "Blue moon" seemed to be a truly modern piece of folklore, masquerading as something old. Then my brother-in-law reminded me that the term was a question in one of the Trivial Pursuit boxes, the "Genus II edition," which was published in 1986. Trivial Pursuit is a fine company for scholars--they keep all their files and they can tell you the source of any bit of information in their games. Yes, they told me, that question came from a certain children's "Facts and Records" book, published in 1985. Where the authors of that book got it, no one seemed to know.

The term, used this two-full-moon way, must have been very, very local before the publication of the children's book, so local that it seemed never to have been written down by amateur or professional astronomers, or by the authors and newspapers which might have been searched by dictionary makers. It certainly was very rare. Perhaps, I thought, it was even made up by the authors of the children's book as a safeguard against plagiarism. This is sometimes done to be able to prove in a law court that a later work was stolen from your own--how else would they have gotten something which you invented? Well, if this is what the authors did, they lost out because the term immediately entered the folklore of the modern world and it has become as living a meaning of the term "blue moon" as any of the earlier ones.

In late December 1990 I published my notes on the origin and development of the term, and posted it to an Internet computer network for folklorists. That month I also received Deborah Byrd's "Astronomy" article from that month in which she attributed "blue moon" to a note in a 1946 edition of "Sky & Telescope." Research eventually pushed that date back to 1943, and to an unnamed Maine almanac.

Deborah Byrd's late 1970's radio program, "Star Date," may in fact have been responsible for spreading the new (or reborn) term. During research for that program she ran across this 1943 "Sky & Telescope" "star quiz" which included a question about two full moons in a calendar month, the answer to which was "blue moon." The term clearly was not commonly known in 1943, and the author of the quiz, L. J. Lafleur, attributed it to a 19th century Maine almanac. I've searched for a Maine almanac with the term in it but to no avail--if any readers have such a thing, I'd be very grateful to receive a copy! On her "Star Date" show Byrd used the "blue moon" term; that probably started the ball rolling.

This is congruent with my original theory that the term was in local circulation (perhaps as local as a single Maine family--the Lafleurs?) until it was made popular in the last decade or two by the media. Until the wire services took it in May 1988, those three media helpers were Deborah Byrd on the radio, the children's book (Margot McLoon-Basta and Alice Sigel, "Kids' World Almanac of Records and Facts," published in New York by World Almanac Publications, in 1985), and the board game Trivial Pursuit. The May 1988 double full moon really lifted the term off the ground by the interest of wire services feeding it to newspapers, radio stations and television newsrooms all over North America, and perhaps the world.

This new "blue moon" has a kind of technical meaning which most of the earlier ones lacked. Perhaps as a result, and although it competes with five other meanings, it will last a whole lot longer. "Old folklore" it is not, but real folklore it is.

Reference:

<http://www.grimmoons.org/1988bluemoon.html>

2/23/99

For a discussion of physical causes of a blue-appearing moon, with bibliography, and a list of blue moons from 1898 through 1999, see: "Once in a Blue Moon," Ronald Lane Reese and George T. Chang, in the *Griffith Observer*, March 1987, pp. 13-20.

\*\*\*\*\*

### SIDEBARS

\*\*\*\*\*

once in a blue moon.

The first appearance in print of this expression goes back to well before the time of Shakespeare--to 1528, in fact. In a little item called *Rede Me and Be Not Wroth* appears:

Yf they say the mone is blewe  
We must believe that it is true.

Making allowances for the fact that the pre-Elizabethians spelled differently from the way we do today, this makes the point that nobody really believed that the moon ever was blue. So once in a blue moon meant never. However, it appears that thanks to physical phenomena like dust storms, cloud banks and ice crystals in the atmosphere, the moon on very rare occasions may appear to be blue. So nowadays once in a blue moon translates best into W. S. Gilbert's famous line from *H.M.S. Pinafore*: "What, never? Well, hardly ever!"

--*Morris Dictionary of Word and Phrase Origins*, William and Mary Morris, Harper & Row, New York, 1977.

\*\*\*\*\*

once in a blue moon

It means extremely infrequently, so rarely as to be almost tantamount to never. From literary evidence the unusual tinge to the face of the moon which led someone to call it a "blue moon" was not observed until after the middle of the last century; nevertheless it is highly probable that this phenomenon had been observed by mariners some centuries earlier, but, like many other notions and expressions long familiar to seafaring men, it did not come to the notice of writers for many, many years. But, with another thought in mind, as long ago as 1528 a rimester published these lines:

Yf they saye the mone is belewe,  
We must believe that it is true.

Then the next year "green cheese" entered the picture in the lines of another writer: "They woulde make men beleue ... that ye Moone is made of grene cheese."

Apparently, then, there were two schools of thought back in the early sixteenth century--one maintaining that "ye Moone" was made of "grene" cheese, and the other stoutly affirming that it was

"belewe." Actually these ancient humorists were just punsters with a taste for metaphor; for by "green cheese," it was not the color but the freshness that was referred to--the moon, when full and just rising, resembling both in color and shape a newly pressed cheese. By "blue cheese" the ancient reference was to a cheese that had become blue with mold, metaphorically transferred, probably, to the comparatively rare appearance of the moon on unusually clear nights when the entire surface of the moon is visible although no more than a thin edge is illuminated. Thus, our phrase "once in a blue moon" may actually date back to the sixteenth-century saying that "the mone is belewe."

--*A Hog on Ice and Other Curious Expressions*,  
Charles Earle Funk, Harper, New York, 1948

\*\*\*\*\*

#### Remaining "Blue Moons" in the 20th Century (times in UT)

1996 July 30 10:35  
1999 January 31 16:06  
1999 March 31 22:49  
\*\*\*\*\*

#### Frequency of Blue Moons

A major Moon phase can happen twice within a calendar month for the simple reason that our calendar no longer pays any attention to Moon phases (even though the word "month" derives from "Moon"). What we call a month, namely 1/12 of a year, is longer than the average length of time from a given Moon phase (say, Full) to the next recurrence of the same phase, which is 29.53059 days. There are 1200 calendar months in a century. In the same century, there are, on the average, 1236.83 Full Moons. The difference is the average number of Blue Moons in a century: 36.83, or an average of one per 2.72 years. Actually, about one year each 19 has two Blue Moons, because its shortest month, February, has no Full Moon at all; for the Eastern Time Zone, the complete list of such years from 1951 through 2050 is 1961, 1980, 1999, 2018, and 2037. Between such years, Blue Moons happen at intervals like 2 years and 7, 8, 9, or 10 months. the bottom line of all this complexity: just under 3% of all Full Moons are Blue Moons.

--*Michigan Spacelog*, July 1985, Jim Loudon  
University of Michigan, Ann Arbor

\*\*\*\*\*

Philip Hiscock has been Archivist at the Memorial University of Newfoundland Folklore and Language Archive since 1979. In the 1970s he did undergraduate and graduate work in Linguistics (mainly dialectology), and in the 1980s he finished an MA in Folklore. His Ph.D. in Folklore is expected in 1994 and deals with folklore and popular culture in Newfoundland in the 1930s and '40s. He has written regular columns on folklore and language for several Newfoundland papers and magazines, and he has also appeared many times on television and radio discussing topics like blue moons.

An earlier version of this article and the recipe for a Blue Moon appeared in *The Plains Planetarian*, Fall 1993. The article was published in its present form in the *Planetarian*, December 1993. Copyright 1993 International Planetarium Society. For permission to reproduce please contact Executive Editor John Mosley, Griffith Observatory, 2800 E. Observatory Road, Los Angeles, CA 90027.

---

For additional interesting information on Blue Moons and a Blue Moon Calculator, please see David Harper's Blue Moon page.

---

return to Planetarian home page

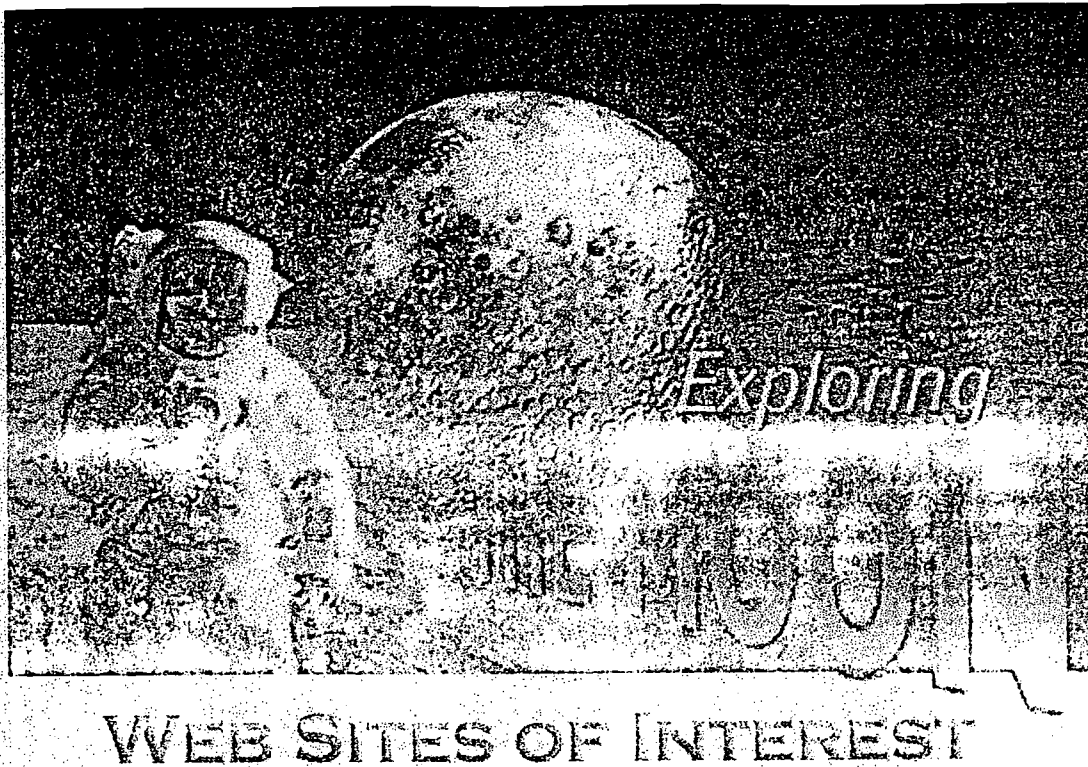

## VIEWS OF THE SOLAR SYSTEM — THE MOON

*Los Alamos National Laboratory*

One of the premier sites for lunar information.

<http://bang.lanl.gov/solarsys/eng/moon.htm>

## WHERE NO MAN HAS GONE BEFORE

*National Aeronautics and Space Administration*

NASA History Office documentation of the Apollo program. Roughly half the text is devoted to preparations for the lunar landings, with the remainder of the book detailing lunar explorations that followed *Apollo 11*.

<http://www.hq.nasa.gov/office/pao/History/SP-4214/cover.html>

## APOLLO: A RETROSPECTIVE ANALYSIS

*National Aeronautics and Space Administration*

NASA History Office study commemorating the twenty-fifth anniversary of the *Apollo 11* lunar landing. Analyzes the progress of Apollo during the 1960s and 1970s.

<http://www.hq.nasa.gov/office/pao/History/Apollomon/cover.html>

## CHARIOTS FOR APOLLO

*National Aeronautics and Space Administration*

NASA History Office site tells the story of the development of the Apollo Command and Service Modules and the people who designed and built them.

<http://cass.jsc.nasa.gov/exp/moon/moonwebsites.html>

<http://www.hq.nasa.gov/office/pao/History/SP-4205/cover.html>

## **LUNAR PROSPECTOR**

*NASA Ames Research Center*

Current mission in orbit around the Moon. Information on the latest scientific results and mission status. Includes information on Moon mythology, a lunar exploration timeline, and an extensive lunar data archive.

<http://lunar.arc.nasa.gov/>

## **THE FACE OF THE MOON: GALILEO TO APOLLO**

*Linda Hall Library*

Excellent exhibition of pre-Apollo rare documents and images. For those interested in the history of lunar exploration. Includes imagery from Galileo and the Paris Atlas.

<http://www.lhl.lib.mo.us/pubserv/hos/moon/cover.htm>

## **EXPLORING THE MOON**

*Lunar and Planetary Institute*

Overview of lunar exploration including a large section on the Apollo program as well as information and links to other mission information sites.

<http://cass.jsc.nasa.gov/moon.html>

## **LUNAR SAMPLES**

*NASA Johnson Space Center*

Great site. Extra bonus: The heading is a hot link to the samples lab.

<http://www-curator.jsc.nasa.gov/curator/lunar/lunar.htm>

## **APOLLO MANNED SPACE PROGRAM**

*National Air and Space Museum*

Fun site, full of historic tidbits of information. Great imagery, spacecrafts, launch facilities, rockets, etc. Short history in text and imagery of each mission.

<http://www.nasm.edu/APOLLO/>

## **MOON FACT SHEET**

*National Space Science Data Center*

One excellent nearside image of the Moon plus specific information about size and orbit. Several interesting links to other lunar and planetary sites.

<http://nssdc.gsfc.nasa.gov/planetary/factsheet/moonfact.html>

## **ICE ON THE MOON**

*National Space Science Data Center*

Includes good imagery and links to latest lunar missions. Timely information about the significance of ice on the Moon. Includes NASA Press Release announcing the discovery of ice on the Moon.

[http://nssdc.gsfc.nasa.gov/planetary/ice/ice\\_moon.html](http://nssdc.gsfc.nasa.gov/planetary/ice/ice_moon.html)

## **MOON INFORMATION**

*National Space Science Data Center*

Collection of interesting sites divided by planet information, mission information, future missions, and a long list of other lunar sites.

<http://nssdc.gsfc.nasa.gov/planetary/planets/moonpage.html>

## **CHRONOLOGY OF LUNAR AND PLANETARY EXPLORATION — MISSION TIMELINE**

*National Space Science Data Center*

Site gives timeline of the planetary exploration with links to the data returned from the missions.

<http://nssdc.gsfc.nasa.gov/planetary/chrono.html>

## **MOON INFORMATION**

*U.S. Geological Survey (USGS)*

Small amount of general information. Good links to other sites of interest, including a Clementine mission image site and lunar images from the Galileo mission.

<http://wwwflag.wr.usgs.gov/USGSFlag/Space/wall/moon.html>

## **SOLAR SYSTEM GUIDE — THE MOON**

*University of Texas*

Excellent page for general public use. Nice imagery, good text, and an abundance of Moon facts.

<http://stardate.utexas.edu/resources/ssguide/moon.html>

## **MOON NOMENCLATURE GAZETTEER**

*U.S. Geological Survey (USGS)*

A listing of lunar features and their locations, with an introduction page.

<http://wwwflag.wr.usgs.gov/USGSFlag/Space/nomen/moon/moonTOC.html>

## **THE NINE PLANETS — THE MOON**

*University of Arizona*

One of the best sites on the Internet for lunar information. Excellent for the general public. Includes good imagery, great text, and lots of interesting links to other great sites.

<http://seds.lpl.arizona.edu/nineplanets/nineplanets/luna.html>

## **FROM EARTH TO THE MOON**

*HBO*

Information about the HBO miniseries plus an added bonus of 360-degree views inside the command module, mission control, and Apollo launch pad 39.

<http://www.hbo.com/apollo>

## **THE LUNAR ALMANAC**

*Reston Communications*

<http://cass.jsc.nasa.gov/exp/moon/moonwebsites.htm>

Site not completed. Of special interest is the Lunar Explorations page and The Moon in Fiction page.

<http://www.reston.com/astro/lunar/almanac.html>

—*Lunar and Planetary Institute, April 1998*

---

*Exploring the Moon ©Lunar and Planetary Institute (1998)*

*Last modified: June 11, 1998*



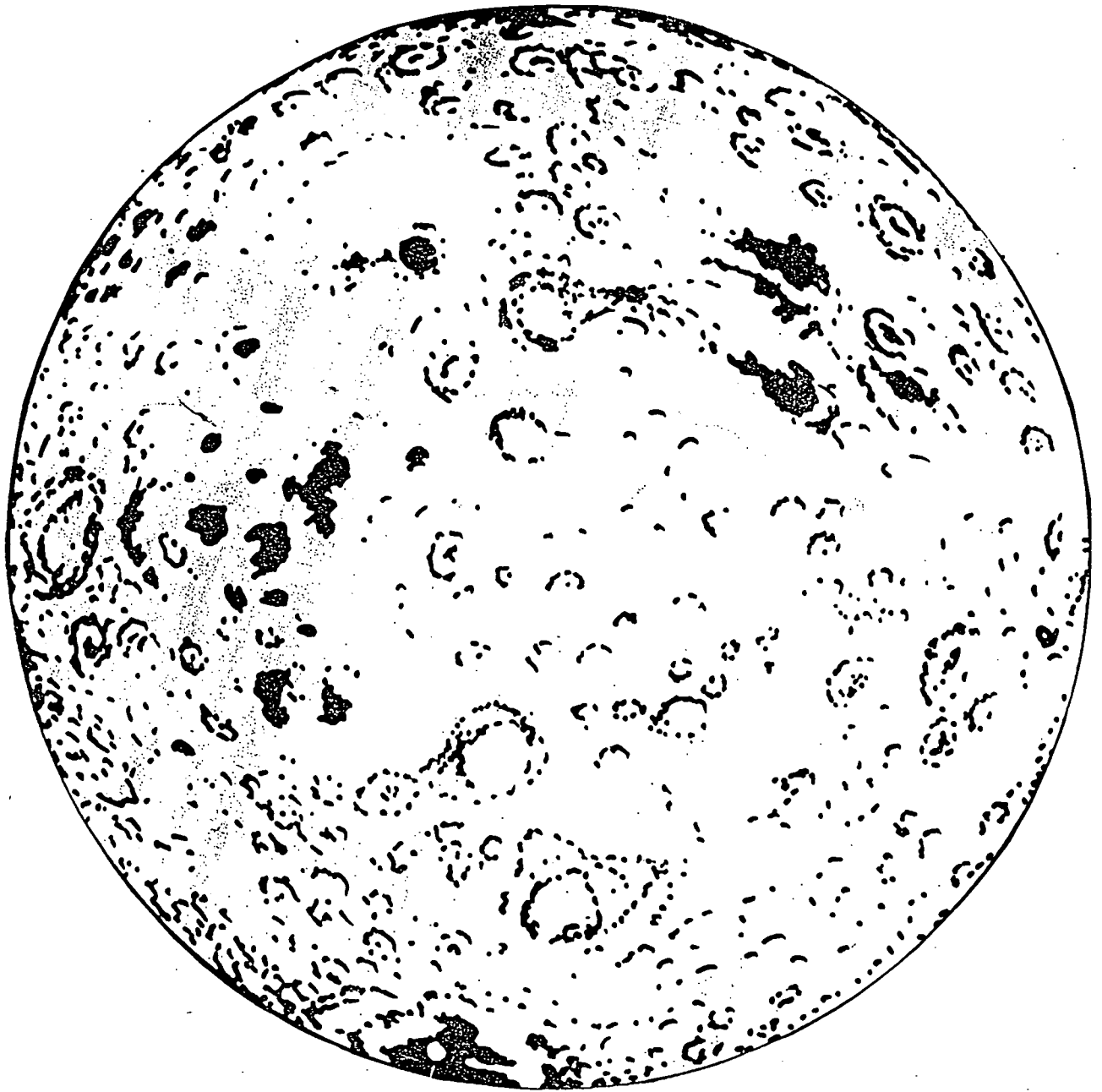

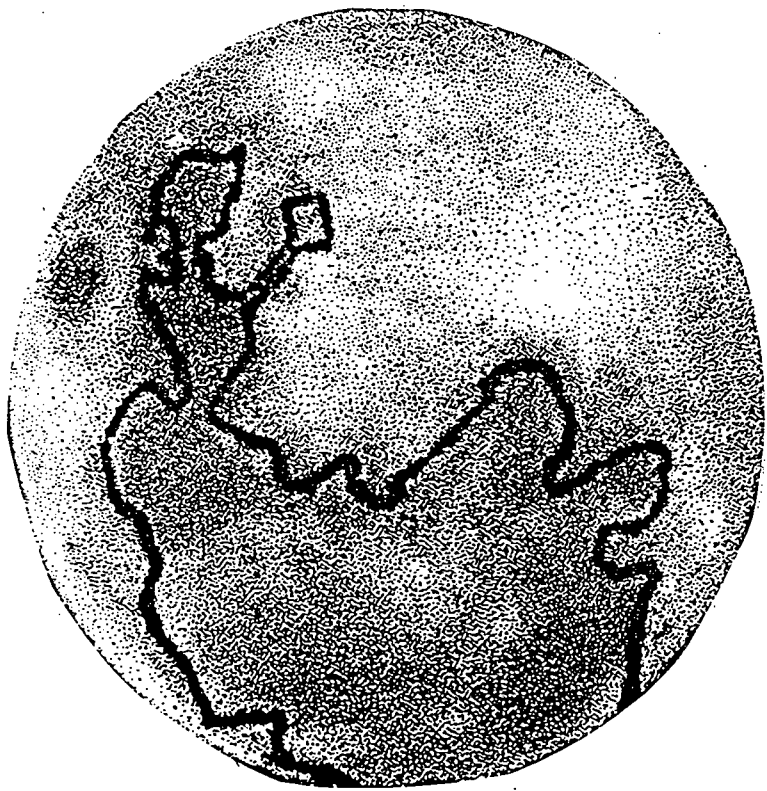
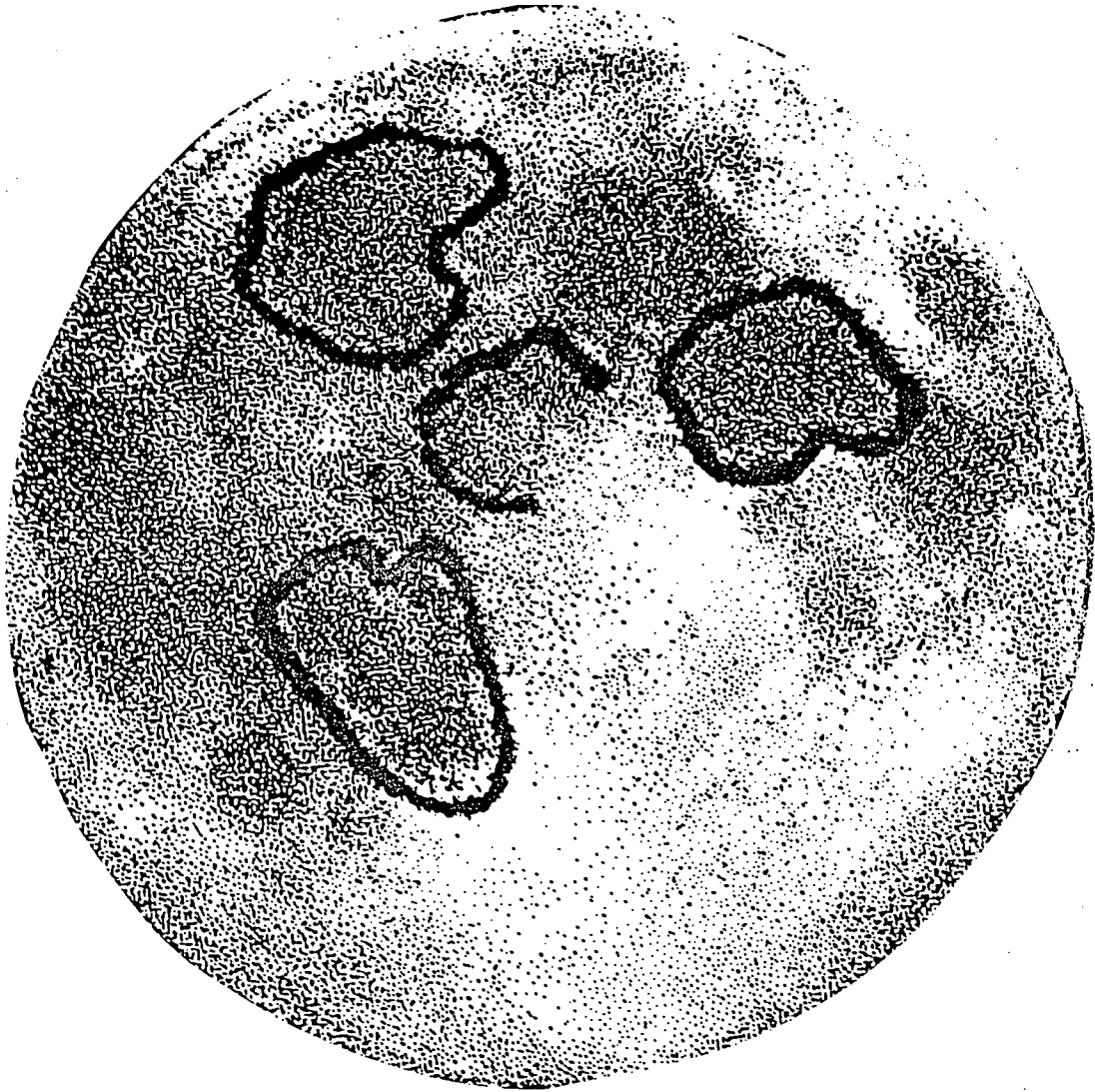

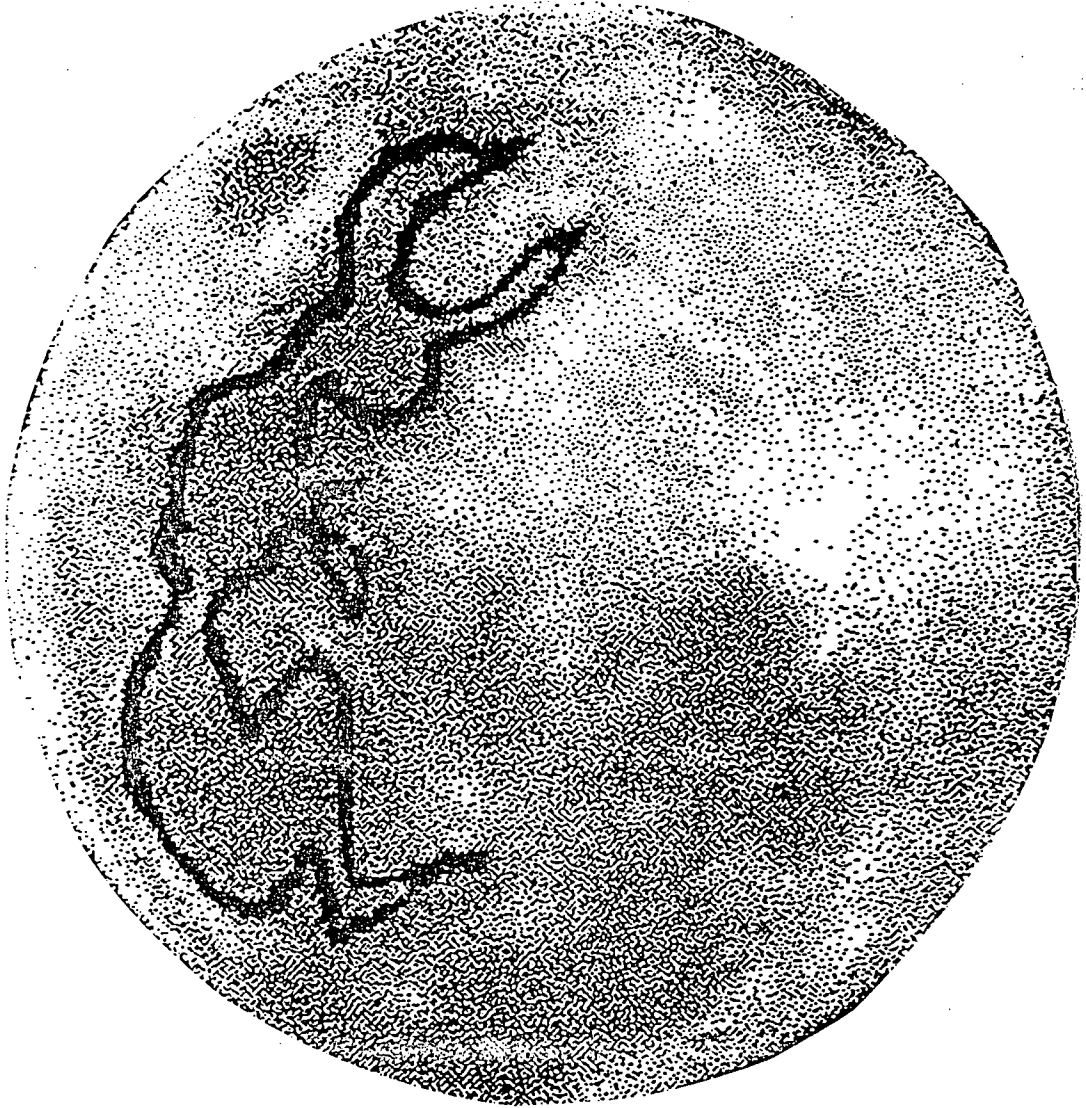

.....  
.....



ERIC  
Full Text Provided by ERIC

PATRICIA HOPKINS  
FEBRUARY 22, 1999  
EDCI 5390

TITLE OF BOOK: THE SEA-BREEZE HOTEL  
AUTHOR: MARCIA VAUGHAN AND PATRICIA MULLINS  
SCIENCE CONCEPTS: WIND, WEATHER, AIR CURRENTS, KITES, NATURAL  
RESOURCES, ENERGY SOURCE

TEKS: 2.7D, 2.10B

RELATED VOCABULARY: WEATHER, TEMPERATURE, BEAUFORT  
SCALE, HURRICANE, GALE, BREEZE, WIND POWER,  
ENERGY, LOW-PRESSURE, HIGH-PRESSURE, ANEMOMETER, WIND VANE,  
RENEWABLE

WINDY DAYS..... SCIENCE IS A BREEZE WITH THESE ACTIVITIES  
ABOUT THE WIND...GET READY TO BE BLOWN AWAY!

OPENING FOCUS-RIDDLES...

WHAT'S STRONG ENOUGH TO KNOCK DOWN A TREE BUT GENTLE  
ENOUGH TO FLOAT A FEATHER?

WHAT CAN YOU FEEL BUT NEVER HOLD?

WHEN THE WIND BLOWS, IT IS RATHER LIKE LETTING AIR OUT  
OF A BALLOON. THE AIR INSIDE THE BALLOON IS AT HIGH  
PRESSURE AND IT RUSHES OUT TO WHERE THE PRESSURE IS LOWER.  
WINDS ALL OVER THE WORLD ARE CAUSED BY DIFFERENCES IN  
TEMPERATURE AND PRESSURE, AND THEY ALWAYS BLOW FROM HIGH TO  
LOW PRESSURE AREAS. SOME WINDS THAT BLOW REGULARLY IN JUST  
ONE AREA HAVE A SPECIAL NAME. OTHER WINDS SWEEP ACROSS THE  
WHOLE EARTH.

THE TWO MOST IMPORTANT THINGS ABOUT THE WIND ARE ITS  
STRENGTH OR SPEED AND THE DIRECTION IN WHICH IT IS BLOWING.  
WE USE A WEATHER VANE OR A WINDSOCK ( A KIND OF LONG CLOTH  
TUBE THROUGH WHICH THE WIND IS FUNNELED) TO SEE WIND  
DIRECTION. WIND STRENGTH IS MEASURED BY THE BEAUFORT  
SCALE, WINDSOCKS, OR BY SPECIAL SCIENTIFIC INSTRUMENTS  
CALLED ANEMOMETERS. THESE MACHINES HAVE SEVERAL SMALL CUPS  
THAT SPIN WHEN CAUGHT IN THE WIND. THE SPEED OF THE SPIN IS  
THEN MEASURED AGAINST A SCALE.

THE WIND IS ONE OF THE MOST PROMISING OF THE RENEWABLE  
ENERGY SOURCES. IT CAN BE USED FOR A NUMBER OF PURPOSES,  
LIKE PRODUCING ELECTRICITY, OR PUMPING WATER. THE WIND HAS  
BEEN USED FOR THOUSANDS OF YEARS TO POWER SAILING SHIPS AND  
WINDMILLS. TODAY IT IS BEGINNING TO BE USED MORE AND MORE,  
AND FOR A VARIETY OF PURPOSES. THE GREATEST POTENTIAL FOR  
USING THE WIND IS FOR THE PRODUCTION OF ELECTRICITY. THE  
WIND IS USED ON FARMS TO PUMP WATER UP FROM UNDER THE  
GROUND. THERE ARE OVER A MILLION WATER PUMPS IN USE, MAINLY  
IN THE USA, CANADA AND AUSTRALIA. WIND POWER HAS GREAT  
POTENTIAL FOR THE FUTURE, AS IT IS RELATIVELY SAFE AND  
POLLUTION FREE. IN THE 20TH CENTURY OUR KNOWLEDGE OF  
AIRPLANE PROPELLERS HAS HELPED US PRODUCE MORE POWERFUL WIND  
MACHINES.

1. MAKING MINATURE KITES.....YOU MAY WANT TO ENLARGE THE PATTERN BEFORE COPING.

1. CUT OUT THE PATTERN AND THEN CUT ALONG THE LINE IN THE MIDDLE. SET ASIDE THE SIDE WITH THE X'S.

2. CUT THE OTHER HALF INTO FOUR STRIPS (ALONG THE LINES). TAPE THE FOUR STRIPS TOGETHER TO MAKE THE KITE'S TAIL. SET ASIDE.

3. ON THE OTHER HALF, POKE THROUGH THE DOT ON THE MIDDLE USING A TOOTHPICK.

4. THREAD THE STRING THROUGH THE HOLE AND TIE ONE END TO THE TOOTHPICK. THIS WILL ANCHOR THE STRING TO THE KITE.

5. TAPE ONE END OF THE STRAW TO THE X ON THE LEFT SIDE OF THE KITE, THEN GENTLY PUSH THE PAPER SO THAT THE OTHER END OF THE STRAW CAN BE TAPED TO THE X ON THE RIGHT SIDE.

6. TAPE THE TAIL TO THE BACK CENTER OF THE KITE AND IT'S READY TO FLY. HAVE FUN!

WHAT TO ASK THE STUDENTS.....HOW WOULD YOU DESCRIBE THE KITE'S MOVEMENTS? WHAT MAKES A KITE MOVE THE WAY IT DOES? (AS AIR RUSHES PAST, IT PUSHES THE KITE UP AND KEEPS IT ALOFT. IT ALSO MAKES THE KITE SPIN.) WHAT WOULD HAPPEN IF WE CHANGED THE SHAPE OF THE KITE?

HOW DOES THE WIND BLOW??? AIR ON THE MOVE...THAT'S WHAT WINDS ARE. HERE IS A QUICK TRICK TO DEMONSTRATE THE MOVEMENT OF WINDS. SLIP A SIX-FOOT PIECE OF STRING THROUGH A PLASTIC DRINKING STRAW. HAVE TWO STUDENTS HOLD THE ENDS OF THE STRING TIGHTLY. BLOW UP A BALLOON, AND HOLD THE END CLOSED. CAREFULLY TAPE THE BALLOON TO THE STRAW; THEN LET THE BALLOON GO. HAVE STUDENTS HYPOTHESIZE ABOUT WHAT THEY OBSERVE. EXPLAIN THAT AS YOU BLEW UP THE BALLOON, AIR WAS FORCED INTO A SMALL SPACE, CREATING AN AREA OF PRESSURE HIGHER THAN THAT OUTSIDE THE BALLOON. BY RELEASING THE BALLOON, YOU CAUSED THE HIGH PRESSURE AIR IN IT TO ESCAPE INTO THE LOW-PRESSURE AIR OUTSIDE, RESULTING IN A RUSH OF WIND. WINDS BEHAVE IN THE SAME WAY: AIR MOVES FROM AREAS OF HIGH PRESSURE TO AREAS OF LOWER PRESSURE.

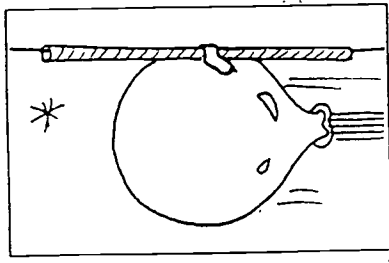



YOU MAY NOT BE ABLE TO SEE THE WIND ITSELF, BUT YOU CAN SEE WHAT IT DOES. THIS SPINNING PAPER PLATE HELPS MAKE WIND "VISIBLE" AND IS GREAT FUN TO CHASE.

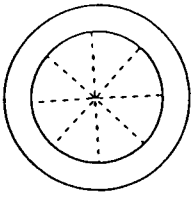

1. CUT A PAPER PLATE FROM THE MIDDLE TO MAKE EIGHT EQUAL, TRIANGULAR FLAPS.

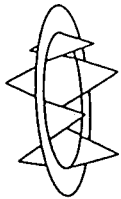

2. FOLD THE FLAPS OUTWARD, ALTERNATING BETWEEN EACH SIDE OF THE PLATE AS YOU GO AROUND.

3. THE SPINNER WORKS BEST ON A WINDY DAY. ROLL IT ON A FLAT PIECE OF GROUND. QUICKLY DETERMINE THE WIND DIRECTION BY WETTING YOUR FINGER AND HOLDING IT IN THE AIR. THE PART OF YOUR FINGER THAT FEELS COOL IS AFFECTED BY QUICK EVAPORATION FROM AIR MOVEMENT, AND INDICATES THE DIRECTION FROM WHICH THE WIND IS BLOWING. SEND THE SPINNER WITH THE WIND AND THEN AGAINST THE WIND. IN WHICH DIRECTION DOES THE SPINNER GO FASTER? HOW EASY IS IT TO CHASE THE SPINNER?

MAKING A PINWHEEL.....USE A PATTERN OR A SQUARE SHEET OF PAPER TO MAKE A PINWHEEL. CUT THE SQUARE DIAGONALLY FROM EACH CORNER TO WITHIN 1CM. OF THE CENTER. BEND EVERY OTHER POINT BACK TO THE CENTER OF THE SQUARE. INSERT A STRAIGHT PIN INTO THE ERASER ON A PENCIL. TRY MAKING PINWHEELS OUT OF DIFFERENT FLAT MATERIALS. WHICH MATERIAL WORKS BEST? HOW CAN YOU MAKE THE PINWHEEL TURN FASTER?

RESEARCH THE HISTORY OF KITES AND HOW THEY HAVE BEEN USED. MAKE A TIME LINE USING A KITE AND ITS TAIL.



alternately, until all are folded.

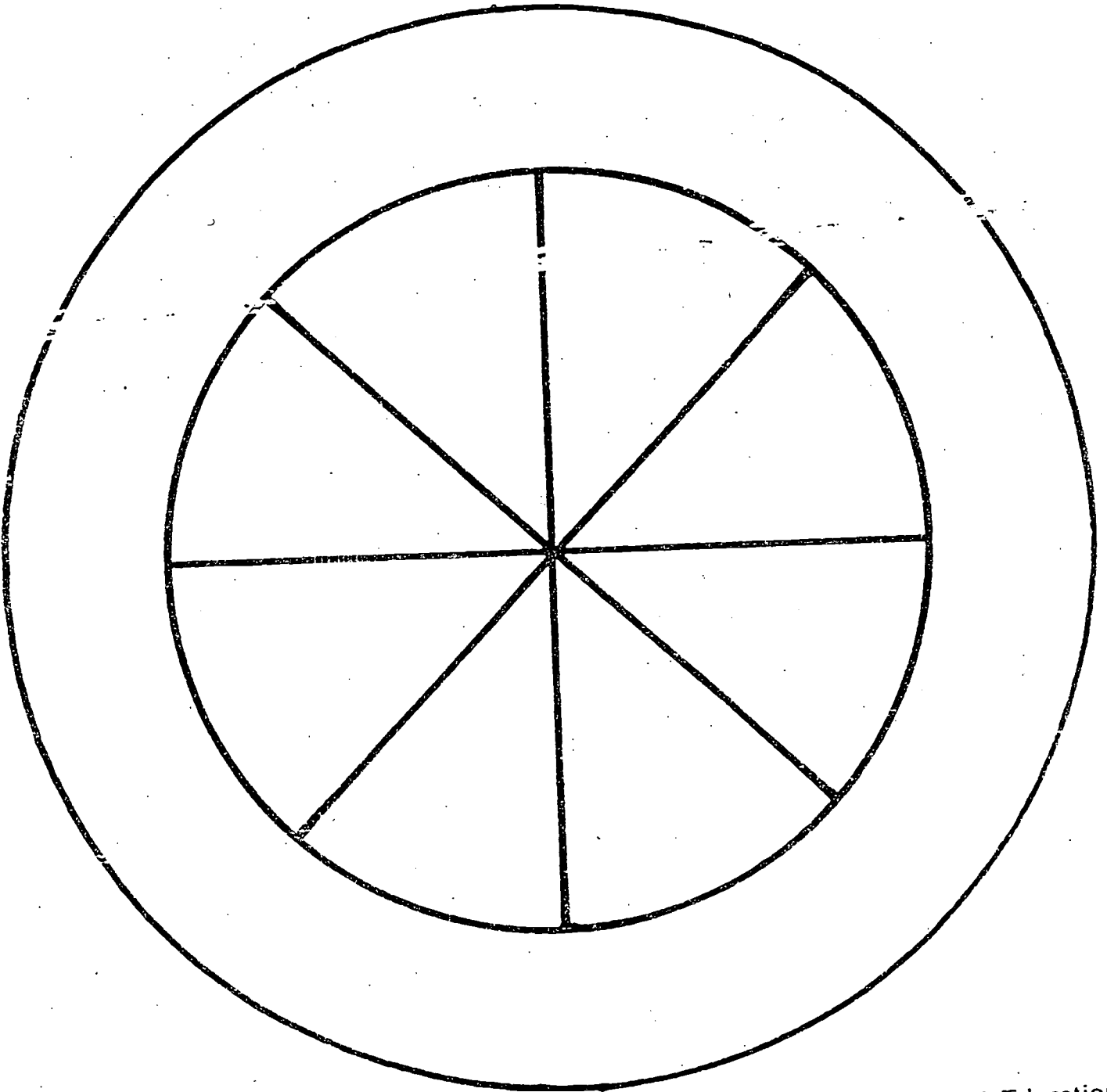

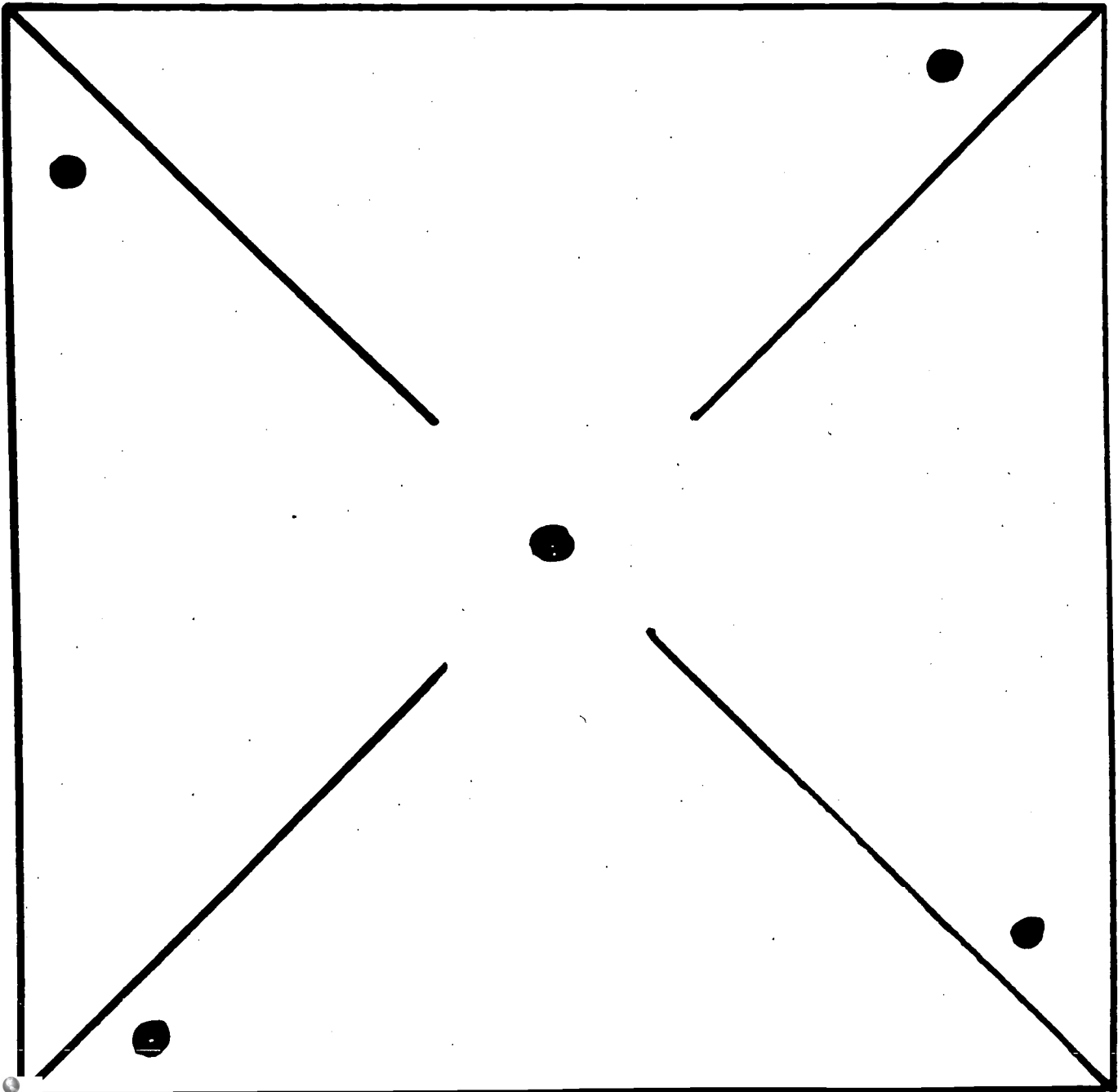
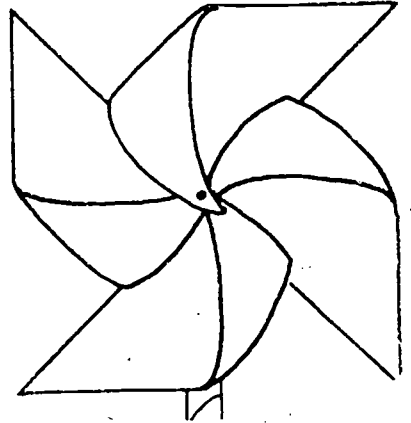
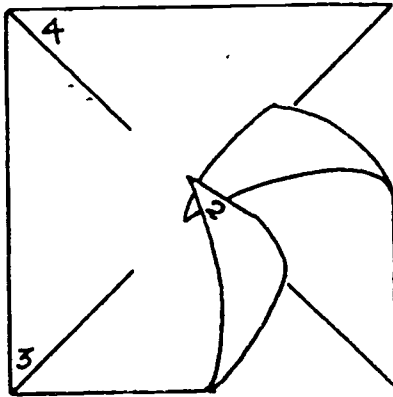
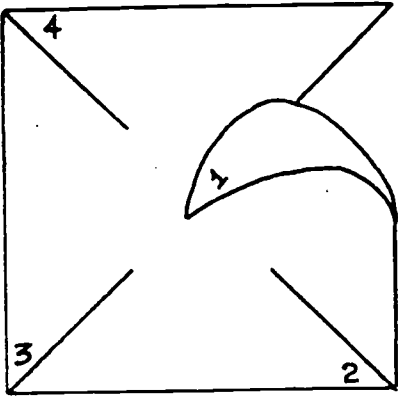

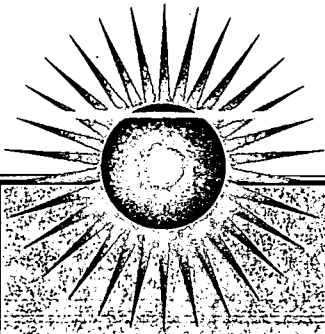

# My Personal Weather Log

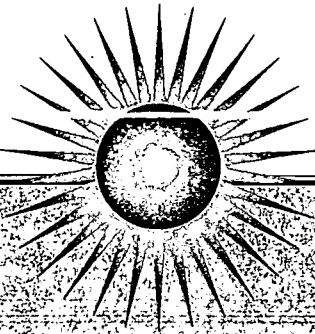

Week of \_\_\_\_\_

 <b>Day</b>	<u>The weather</u> today is ...	<u>The temperature</u> is ...	<u>The wind</u> is ...
<b>Monday</b>			
<b>Tuesday</b>			
<b>Wednesday</b>			
<b>Thursday</b>			
<b>Friday</b>			

# How Strong is the Wind?

 The Beaufort Scale, below, is a measure of how strong the wind is blowing. On the back of this page, see if you can think of definitions of your own. (Such as: Moderate breeze—Hold on to your baseball cap). Then, each day, guess how strong the wind is and fill it in on your Personal Weather Log. 

**Calm** (0 mph)—**Smoke rises.** 

**Light air** (1 to 3 mph)—**Smoke drifts.** 

**Slight Breeze** (4 to 7 mph)—**Vanes move.** 

**Gentle Breeze** (8 to 12 mph)—**Leaves and twigs move.** 

**Moderate Breeze** (13 to 18 mph)—**Branches move, flags flap.**

**Fresh Breeze** (19 to 24 mph)—**Small trees sway.**

**Strong Breeze** (25 to 31 mph)—**Large branches move, flags beat.**

**Moderate Gale** (32 to 38 mph)—**Flags extend.**

**Fresh Gale** (39 to 46 mph)—**Twigs break.**

**Strong Gale** (47 to 54 mph)—**Signs and antennas blow down.**

**Whole Gale** (55 to 63 mph)—**Trees uproot.**

**Hurricane** (64+ mph)—**Widespread destruction.**

**Activities to Use Along with *The Sleeping Porch***  
by Karen Ackerman (Activities by Dean Garza)

## Summary

The story in the book, *The Sleeping Porch* is one that portrays the flight of one family from the city to the country. In doing this their environment changes tremendously. Along with bigger spaces they start to realize the changing of the seasons and the wonders of the outdoors. The sleeping porch is an important reminder to the family of their experience and turns into a gathering place for the family.

This book opens a wide door into varied science related activities. Just from the outset the reader is hit with the use of the seasons to carry the story. This along with other weather and earth science activities can be created using the story of *The Sleeping Porch*.

## TEKS and Science Related Concepts

-5.3, 5.4, 5.6, and 5.11

- Water Cycle, Seasonal/Environmental Change and Plant Life

## Activities

1. **Identifying Environment:** This would be introduced directly after the first reading of the story. Obviously, the environment described in the book is unlike that of South Texas. Have students quickly brainstorm where they believe the story takes place. (Remember to use clues from the story) When done ask the children to write down the main differences they noticed in the environmental sense. Have them keep in their notes for reference

later.

**2. Introduction of Water Cycle:** Based on the fact that most students will site snow as the biggest difference in the environment of the book, the water cycle can easily be introduced. After quickly reviewing the main points of the story ask the children if they know what makes snow happen? Writing responses is optional but gains more interest. After a few responses show a posterboard of the watercycle on the board to the class. Have the children identify the parts like condensation, evaporation, etc. After identification have them add the cycle to their notes and introduce the “Humidity Experiment” for home activity.

**3. Humidity Experiment:** To be introduced at the end of the water cycle lesson. Have the children shortly before dismissing from the water cycle activity pull out a blank sheet of paper. On the paper they may write anything they want as long as it is a complete sentence(and no profanity). Next have them record in their notes using the scientific process, the characteristics of the paper and what is written on it. They are to take this home and leave it outside or tape it to a window. Because of the humidity in Corpus Christi it should be soaked by the morning or damp. In class they should record any changes to the paper ,if it is still legible and if it agrees with their hypothesis.

**4. Seasonal Change:** After a brief review of the story remind the students that the changing of the seasons was a big part of the story. Ask the children what the names of the season are and list on board. Then list as Fall, Winter, Spring, Summer and Autumn. Go over the characteristics of each and if South Texas has those characteristics.

Since South Texas does not ask the children to explain what seasons are the most constant. Have the children draw on posterboard the names of the season leading into the next in a circular fashion. By each season they are to write the characteristics of that season.

Display best ones on bulletin board.

**5. Seasonal Trees:** Now that the students are familiar with the seasonal characteristics have them use them to identify environmental patterns. Give each child a pattern tree with just branches, they will need five in all. For each tree they are to draw what characteristics are most evident, like in the fall the leaves fall off and it turns cold. Using their crayons they will color the other trees of the season.

**6. Seasonal Research:** Have the children each pick a state other than Texas and research their weather during a particular season. After which they will compare it to Texas during the same season and share the results. The results will be shared in another class. The library may be needed or use encyclopedias if they are in the classroom.

**7 & 8. Planting Activity:** This activity goes along with the end of the story when the family is planting in the spring time. Have the following materials- Plastic cups, pinto beans, water, soil and cotton. In the first activity we will give every two students a cup and pinto bean. The teacher will first instruct the students to use the scientific process to record the experiment. After, the teacher will fill every cup at the most half full of soil. The pinto bean should be at the bottom of the soil. Dampen the soil with water and display the cups in an isolated part of the room. This will result in a growth from the bean

after days of watering and the students should record changes. The very next day after using the soil and the bean, the experiment should be repeated using cotton instead of soil. This will show the roots more clearly. Have designated students take daily care of the plants and have students share results later along with hypothesis and theories.

9. Seasonal Findings: Have students share their findings on different states seasonal weather compared to Texas. Keep under two minutes for each presenter.

10. Plant Life: After a week or so have the groups take their cups done in activity 7 & 8. Then have one person in the group describe their plants and the other present the group's hypothesis and theory or theories.

### References

Ackerman, Karen. *The Sleeping Porch*. New York: Morrow Junior Books, 1995



# SEASONAL TREE

-COLOR THE TREE DEPENDING ON THE SEASON & DECORATE BACKGROUND  
EX. SPRING TREE HAS LEAVES & FRUIT WITH SUNSHINE

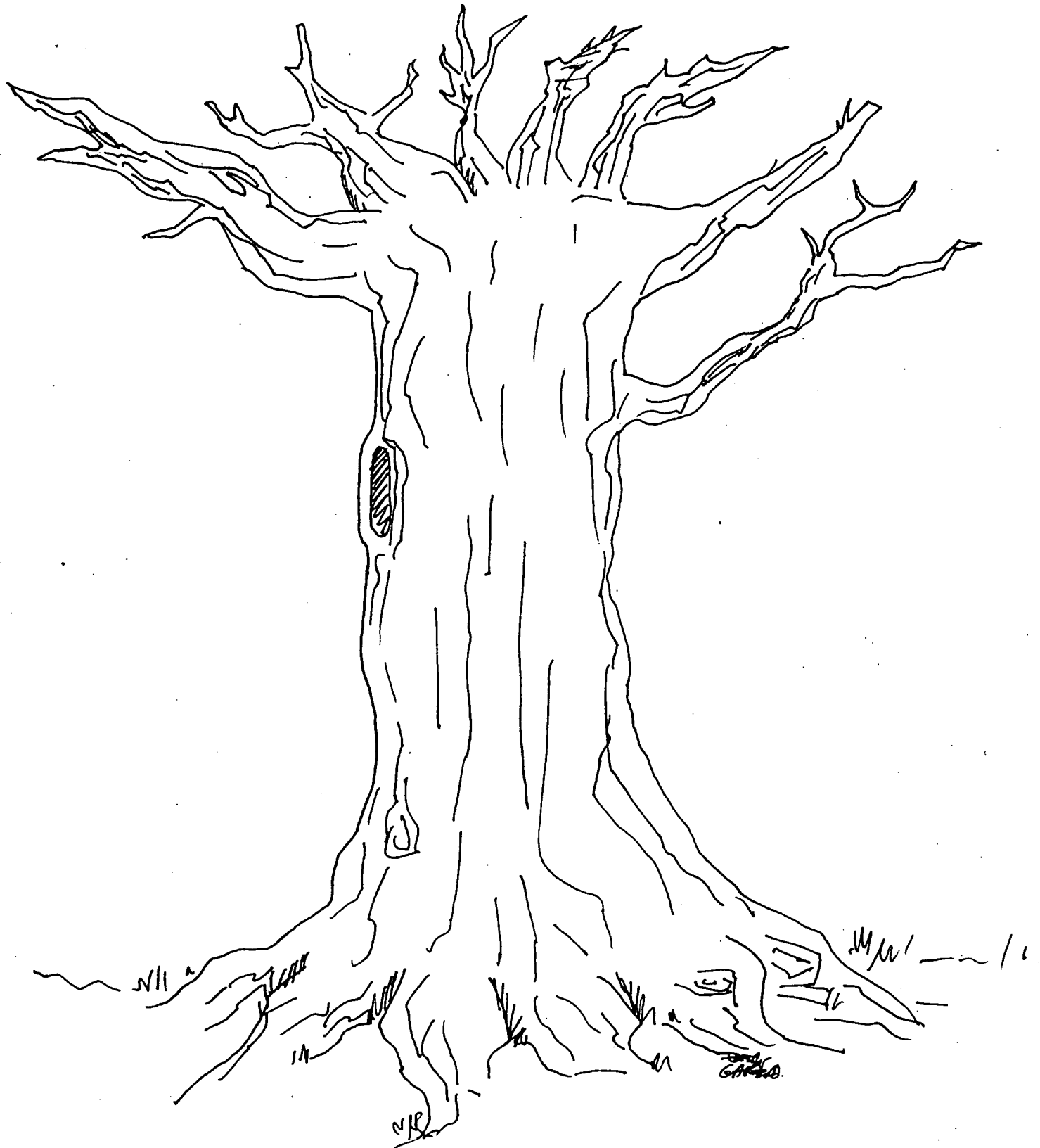

**WELCOME TO THE SEA OF SAND**

BY JANE YOLEN

New York: G.P. Putnam's Sons, 1996

Jenny Cos  
Teaching Science Through Children's Literature  
Dr. Malcom Butler  
April 5, 1999

## Welcome to the Sea of Sand by Jane Yolen

### Summary

This book is a wonderful introduction to the world of the desert - specifically the desert of the American Southwest. We learn of many of the plants and animals that are part of this unique habitat through both the poetic text and the beautiful illustrations. The book includes adaptations that plants and animals have made in order to survive in this land of harsh contrasts. The desert is a land of many colors.

### Science and Content-Related Areas

Desert habitat, rock formation, animals, plant life, adaptation, animal homes, colors, climate zones, transpiration

### TEKS

K.1, K.2, K.3, K.4, K.5, K.6, K.7, K.8, K.9  
1.1, 1.2, 1.3, 1.4, 1.5, 1.6, 1.7, 1.8, 1.9  
2.1, 2.2, 2.3, 2.4, 2.5, 2.6, 2.7, 2.8, 2.9, 2.10  
3.1, 3.2, 3.3, 3.4, 3.5, 3.6, 3.7, 3.8, 3.9, 3.11  
4.1, 4.2, 4.3, 4.4, 4.5, 4.7, 4.8, 4.10, 4.11  
5.1, 5.2, 5.3, 5.4, 5.5, 5.6, 5.9, 5.11, 5.12

## ACTIVITIES

### 1) Desert Land Formation

This activity is a hands-on way of illustrating the diverse land formations found in the desert. Talk about the differences between a mesa, a butte, a canyon, an arroyo, etc. Illustrate with drawings or photographs. Discuss the power of wind and water in carving out the topography. Display these near the activity area so that students can refer back to them. Spread a waterproof sheet or tarp on the floor. Place a small hard plastic swimming pool on the sheet and fill it with sand. Mix in enough water so that the sand is moldable. Have children work in pairs and explore molding the sand into different land formations.

Definitions: mesa-a large flat-topped hill or mountain that stands alone  
butte-a flat-topped, steep-sided hill carved from a mesa by wind and water  
chimney rock-a thin tower of rock carved from a butte by wind and water  
arroyo-a deep gully cut by a usually dry stream  
canyon-a deep gorge, usually with a river flowing through it  
gorge-a narrow steep-sided valley  
gully-a narrow channel cut in the soil by flowing water  
oasis-a fertile spot in a desert, with a spring or well of water  
playa-a desert basin that becomes a lake after a heavy rainfall  
erosion-the processes or circumstances by which the surface of the Earth is worn away

Activity found in Frank Schaffer's School Days, April/May/June 1993, p.32.

### 2) Saguaro Silhouettes

Show students the illustrations from several books, as well as photographs, of the Southwest landscape at sunset. Talk about the colors they see as well as the silhouettes of rock formations and plant life. Show students that a silhouette is a dark shadow or outline seen against a lighter background. Tell them that they will each create

their own desert sunset. Part 1: Give each student a large piece of white construction paper or watercolor paper, a paint brush, a container of water, and a set of water colors. Ask students to paint the whole paper with the colors of a sunset. Part 2: Show the students how to draw a silhouette of a desert skyline on black paper. Then they should cut it out and glue it onto the DRY watercolor painting.

Activity found in Frank Schaffer's Schooldays, April/May/June 1993, p.27.

### 3) Animal Adaptations

Discuss the harsh living conditions of the desert habitat: very little water or a lot of water all at once, very hot for most of the year and yet freezing temperatures at other times. Ask students how they think animals are able to live in the desert. Record their ideas. Define the term adaptation and give an example such as jackrabbits who lose extra body heat through their large ears. Many animals hunt for food only at night and stay in their cool underground homes during the day(ex: rattlesnakes and prairie dogs). The gilias keep their bodies off the ground in order to avoid absorbing the heat from the ground. They also have strong claws for digging. The desert tortoise loses very little water because it has developed waterproof skin. Some animals get extra fluids by eating prickly pear fruits or other plants and seeds. Many of the books in the bibliography illustrate these adaptations.

### 4) Timeline of Saguaro Cactus Growth

a) Before reading any books specifically about saguaros, ask children how tall they think saguaros grow. Record their answers. Then either have them measure out a 30 - 40 foot long piece of string or using a tape measure, see if they can find something around the school that equals that height (perhaps the height of the school, a palm tree or three times the height of a basketball hoop). Lay out the string and ask students to estimate how many kids can fit head to toe along the string. Then measure how many actually do fit!

b) Ask students how old they think saguaros can live to be. Then tell them that saguaros can live for over two hundred years. When a saguaro is ten years old, it is only 5-6 inches high. Saguaros don't start growing arms until they are about 75 years old (about the age of your students' grandparents or great-grandparents). Depending on

the age of your students, you could create a timeline with them beginning in 1800 when a saguaro fruit seed begins to grow on the desert floor. With younger children, you could discuss events in history such as when the first car was built or airplane flown or train built or space ship flown to the moon, and then use pictures or photographs to illustrate these events.

Saguaro information from Webs of Life: Saguaro Cactus by Paul Fleisher.

## 5) Desert Plant Study

Review the harsh living conditions in the desert and the specific effect these conditions have on plant life. Discuss some of the adaptations plants have made in order to survive. Cacti swell and contract in order to store water or conserve moisture through less surface area. Their spines are modified leaves that both protect it from predators and keep the plants warm during extremely cold weather. Many plants only have leaves and produce flowers during rapid growth periods when it rains. Many plants have very long roots that spread out just under the surface of the ground in order to collect as much water as possible when it rains. Other plants have very small leaves such as the mesquite tree in order to avoid losing a lot of water through surface area(transpiration).

Display an assortment of desert plants. Explain that those plants that store water are called succulents. Cut open several and look at the structure of the plant. Note the thick waxy skin that holds in water and the juicy pulp inside. On some plants it is also easy to see the tubes that conduct the water through the plant. Make sure that you make magnifying glasses and a microscope available to the students to use in their exploration.

Information found in Eyewitness Books-PLANT by David Burnie, Dorling Kindersley.

## 6) Constructing a Saguaro Cactus

Study the inside structure of a saguaro cactus. Brainstorm what recyclable and/or art materials the class could use to construct a saguaro in the classroom. Over a period of a week, ask the students to collect the recyclable materials from home and bring them to school. Materials such as newspaper for paper mache, oatmeal canisters, pringles cans, etc are good possibilities. You will need to

get large masking tape, thin wood sticks such as those used in making kites, and paint ready. You may choose to have half the class work on a paper mache cactus and the other half on a recyclable cactus. A large box with either some books or bricks in it makes a good anchor or base.

Paper Mache: either use liquid starch, wallpaper paste, watered down Elmer's glue or wheat paste. Dip strips of newspaper in the mixture and skim off extra paste between your thumb and finger. Then wrap the strips around the structure. When dry, it can be painted.

After the paint has dried, toothpicks can be poked through for the spines.

## 7) Cooking with Cactus

There are many cultures that use cacti as a food source. Both Native American and Mexican peoples use the fruit from saguaro and prickly pear and the pads after removing the spines. This is especially true today in our part of South Texas where cacti are plentiful. There is even an annual Cooking with Cactus festival in Kingsville. Kingsville Tourist Infoline: 361-592-8516

See attached recipes for prickly pear cactus or nopalitas found in the Texas Highways Cookbook by Joanne Smith.

## 8) Camouflage

Many of the animals in the desert survive due to the way they blend into the environment. Talk about the term camouflage and ask students to think about what colors and patterns help conceal animals who live in the desert. Have a selection of animal photographs available to illustrate this phenomenon. Point out the interesting scales and feathers that animals have developed to camouflage themselves. Some animals even change with the season.

Pictures available from the Teacher Resource Center, TAMU-CC

## 9) Animal Classification

Read through Welcome to the Sea of Sand again. Hang up a large piece of chart paper and create four columns with the headings REPTILES, MAMMALS, BIRDS, INSECTS, and AMPHIBIANS. Review the characteristics of each category with the class. As you read, ask your students to decide which category each animal in the story falls into. Some animals will require some discussion such as taratula and centipede.

## 10) Card Match

Play a matching game using pictures/names on one card and the corresponding description/definition on the other card. This can be a whole class activity or an individual challenge. Below is a list of words and their descriptions/definitions that could be used.

- \*saguaro - I can live to be two hundred years old and yet my flowers only bloom for 24 hours.
- \*mesa - I am a large flat-topped hill or mountain that stands alone
- \*gila - I have sharp claws for digging and I hisssssssss.
- \*rattlesnake - I detect my prey by the heat of their bodies. I smell with my tongue. I swallow my prey whole.
- \*spadefoot toad - I live deep in the mud until the rains come. My young hatch from eggs.
- \*scorpion - I have a curved tail. I carry my young on my back.
- \*elf owl - My home is in a living saguaro and I hunt at night. I can turn my head all the way around.
- \*arroyo - I am usually dry. When it rains, I become a raging river.
- \*kangaroo rat - I zigzag when I run in order to evade my predators. I hunt for seeds at night. I live in a hole underground.
- \*tortoise - I like to eat prickly pear fruit. I carry my house with me. My skin is waterproof.
- \*roadrunner - I eat lizards. I run faster than I fly.
- \*cholla - My stems fall off easily and stick to people and animals. That is how I start new plants all around me. I have spines.
- \*jackrabbit - I cool myself off through my ears. I am very fast.
- \*gila woodpecker - I make my home in a hole in a saguaro. I love to eat the insects that try to eat the saguaro.



- \*mesquite tree - I have bark on my trunk. I have many small leaves with which I provide shade for people and animals. Sometimes I grow a seed pod of beans.
- \*javelina - I have small hooves. I root for insects and fruits on the ground. I snort and grunt a lot.
- \*zebra-tailed lizard - I have a striped tail and scales. Roadrunners like to eat me.
- \*mule deer - I have antlers. I listen carefully to see if a mountain lion is nearby.
- \*coyote - I howl and bark to communicate with my brothers and sisters. I like to eat saguaro fruits.
- \*tarantula - I have eight furry legs. Some people are afraid of me but they don't need to be.
- \*big horn sheep - I have curved horns. I am a plant eater.
- \*ocelot - I keep cool in caves and burrows during the day. I have light brown fur with a black pattern on it. I am in the cat family.
- \*bat - I fly at night. I love to drink the nectar from the saguaro flowers. I am a mammal.
- \*succulent - I have thick waxy skin. I can grow and store water inside me.
- \*vulture - I circle the sky looking for my dinner. I have a hooked beak. I feast on the foodscraps someone else has left behind.
- \*mountain lion - I come down from the mountains to hunt for food. I am the largest predator in the desert.
- \*black widow spider - I have eight legs and have a red hour-glass pattern on my back.

## Bibliography

- Bash, Barbara, Desert Giant: The World of the Saguaro Cactus, San Francisco: Sierra Club Books, 1989.
- Booth, Bibi, Richard Brook, Shelly Fischman, LouAnn Jacobson, Shelley Smith and Mary Tisdale, "The Colorado Plateau: High and Windswept," Science and Children, March 1999.
- Burnie, David, Eyewitness Books - PLANT, New York: Alfred A. Knopf, 1989.
- "The Desert," Frank Schaffer's Schooldays, April/May/June 1993.
- Fleisher, Paul, Webs of Life: Saguaro Cactus, New York: Benchmark Books, 1998.
- Guiberson, Brenda, Cactus Hotel, New York: Henry Holt, 1991.
- Hirschi, Ron, Discover My World: Desert, New York: Bantam Books, 1992.
- Kalman, Bobbie, What is a Biome?, New York: Crabtree Publishing, 1998.
- MacQuitty, Miranda, Eyewitness Books - DESERT, New York: Alfred A. Knopf, 1994.
- Miller, George, Landscaping with Native Plants of Texas and the Southwest, Stillwater, MN: Voyageur Press, 1991.
- Smith, Joanne, Texas Highways Cookbook, Austin, TX: University of Texas Press, 1986.
- Wright-Frierson, Virginia, A Desert Scrapbook: Dawn to Dusk in the Sonoran Desert, New York: Simon & Schuster, 1996.
- Yolen, Jane, Welcome to a Sea of Sand, New York: G. P. Putnam's Sons, 1996.

# Desert Landforms

Do this science activity with a partner.  
Lay newspaper around your workspace.  
Work with the sand in the box.

Materials needed:

- large, shallow box
- sand
- bucket or bowl of water
- newspaper

## 1. Sand Dunes

*Sand dunes—mounds of sand that have been piled up by the wind*

Use your hands to shape dunes out of dry sand.

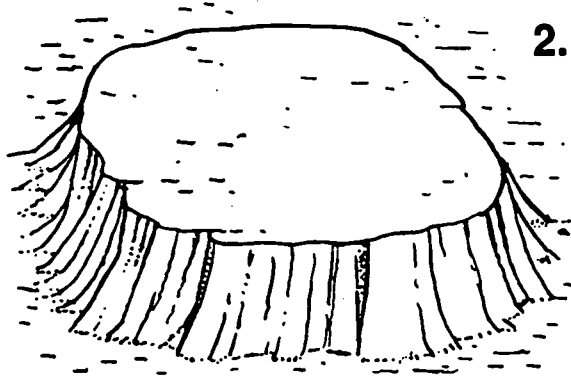
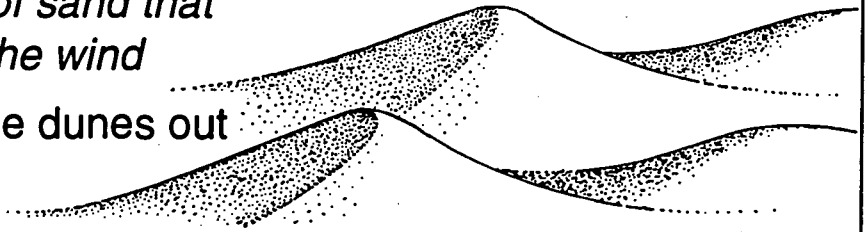

## 2. Mesa (MEH suh)

*Mesa—a large flat-topped hill or mountain that stands alone*

Add water little by little to your sand so that you can mold it. Use your hands to build a mesa.

## 3. Butte (BYOOT)

*Butte—a flat-topped, steep-sided hill carved from a mesa by wind and water*

Use your hands to act like wind and water and carve a butte from your mesa.

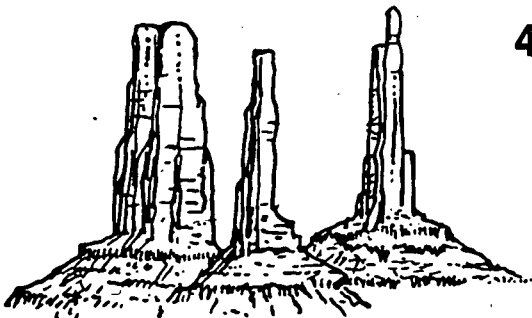
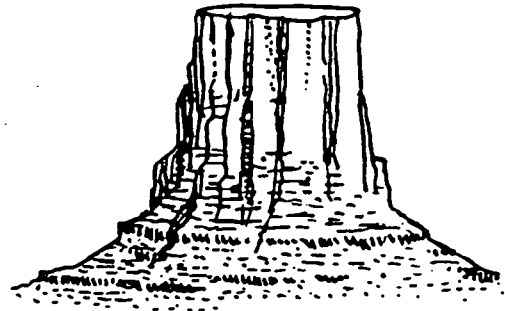

## 4. Chimney Rock

*Chimney rock—a thin tower of rock carved from a butte by wind and water*

Use two fingers to gently wear away part of your butte, leaving a chimney rock.

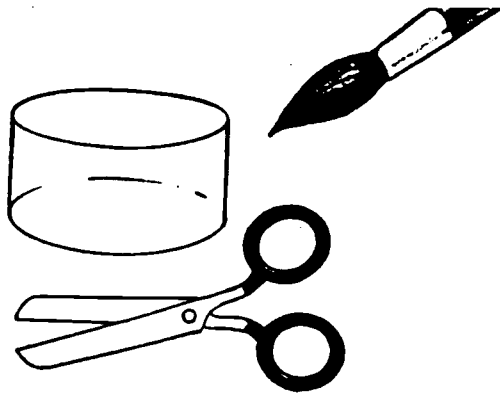

## Art

### Saguaro Silhouettes

Desert sunsets are beautiful. Students can make their own striking sunsets with this simple project.

Materials needed: white paper, black construction paper, watercolors, paintbrush, scissors, glue, pencil

#### Directions:

1. Paint a colorful sky that fills the white paper. Use reds, oranges, and yellows or blues, pinks, and purples.
2. Draw a saguaro cactus on the black construction paper. You may want to include arms and blossoms on the cactus. Cut it out. Cut a strip of black paper and then cut along one side to make curves. This will be the desert ground.
3. Glue the cactus and ground on the painted paper to complete the project.

Discover plants, animals, and landforms of the desert with the reproducible pages that follow.

—Sara E. Freeman  
Boulder, CO

A desert is a region that receives little rain. A desert may be sandy and desolate, mountainous and rocky, or salty and flat. Help students learn about the desert with this diversified unit.

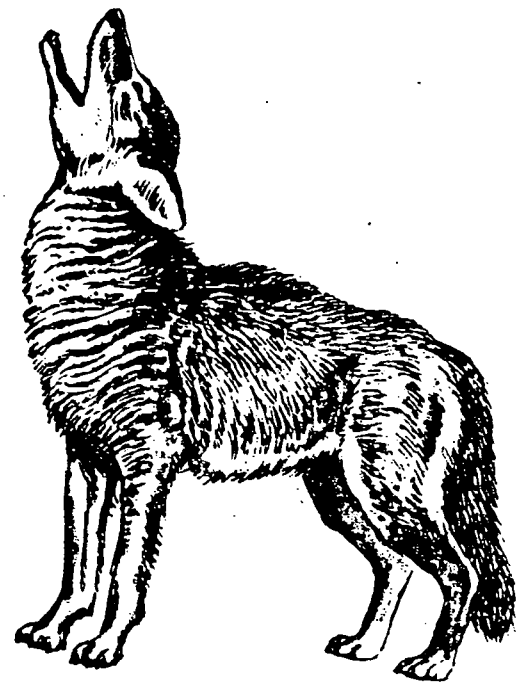

Prickly pear (nopal) gets a lot of bad press for its spines and glochids (barbed hairs), but, in fact, the humble cactus enjoys a strong, but mixed following . . . or, at least, a public of sorts. The Coahuiltecan Indians dried the fruit like figs and pounded the skin into flour. Today, people like the young fruit breaded and fried, or added to omelets, or made into candy. *Ensalada de nopalitas*, or cactus salad, is another favorite, as is prickly pear jelly.

Other serious aficionados, however, take the cactus *au naturel*. White-tailed deer depend on the barbed fare for about 30 percent of their annual diet. The javelina (collared peccary) demands enough for 60 percent of its diet, and if the cactus is plentiful, enough for 100 percent of the wild pig's water supply. For that matter, even cattle sometimes prefer prickly pear to grass, if the rancher caters by burning off the spines. Wild turkeys like the seeds; bees like the nectar.

Nearly everyone who has tried it describes picking the fruit (*tuna*) as "he-e-ell-laceous!" Still, they go looking for the red, ripe *tuna*, wearing thick leather gloves, if not a suit of armor, and pick the fruit with the longest tongs they can find. Then, holding the *tuna* on a long spear of some kind, they burn the stickers over a flame and scrape away the residue with a sharp knife. Even then, peeling the fruit requires rubber gloves, to prevent purple-dyed hands.

By the way, when you go out picking the fruit, watch out for snakes and wasps; they like it too.

Writer and photographer Frank Beesley, who researched the prickly pear for *Texas Highways*, May 1982, offers the solution:

If you aren't prepared to go through all that, just buy some of the prepared prickly pear products in highway specialty shops.

If you insist on making your own, try this recipe from Miguel Ravago of Austin's Fonda San Miguel, or cactus jelly (see p. 110).



*Tequila Soup combines vegetables, herbs, and tequila.*

### *Ensalada de Nopalitas*

- 2 cups nopal cactus
- 2 medium tomatoes, chopped
- 3 tablespoons olive oil
- 4 teaspoons red wine vinegar
- ¼ teaspoon oregano
- ½ cup white onion, chopped fine
- ½ teaspoon salt
- 6 sprigs fresh cilantro
- freshly ground pepper
- lettuce and sliced avocado for garnish

Mix all ingredients in a large bowl, and set aside for about an hour. Before serving, garnish with lettuce and avocado slices.

Another bite of Mexico comes to friends of Dallas clothes designer Cristina Barboglio Lynch in the form of *salsa ranchera*, semi-prepared and delivered right away to friends especially fond of *huevos rancheros*. "But it's HOT," she warns, "so those who like a milder sauce add more tomatoes. But this recipe I got from my father in Mexico, so I make it his way":

### *Salsa Ranchera de La Barboglio*

- 4 medium tomatoes
- 6 chiles (jalapeños)
- ½ clove garlic, minced
- up to ¼ cup water (if needed)

An unusual jelly is made from the fruit (*tuna*) of the prickly pear cactus. This recipe is from *Texas Highways'* May 1982 feature on the prickly pear.

### *Cactus Jelly*

1 gallon cactus *tunas*, gathered carefully (see p. 40)  
water, enough to show through the fruit

Prepare the fruit, peel, and cut into quarters. Place in a saucepan, seeds and all, with water. Bring to a gentle boil, cover, and allow the fruit to cook for about an hour. Strain the juice from the pulp and seeds.

3¾ cups cactus fruit juice  
½ cup lemon juice  
1½ boxes fruit pectin (Sure-Jell)  
6 cups sugar

Add lemon juice and fruit pectin to the strained juice. Bring mixture to a boil and add sugar. Allow the mixture to cook for 3 minutes.

Remove the jelly from heat and allow to cool for 45 minutes. Skim off foam and pour the jelly into hot, sterilized jars. Seal the jars immediately with canning lids or allow the jelly to set and seal it with melted paraffin.

Alternative recipe, from Betsy Simpson of San Antonio:

### *Betsy's Cactus Jelly*

2¾ cups cactus juice  
½ cup lemon juice, strained  
7 cups sugar  
6-ounce bottle Certo fruit pectin

Juice: After gathering and preparing 4 quarts of fruit, wash fruit in a colander, cut each pear in half, and remove the blossom end. Place the fruit in an 8-quart pan and add 1 cup water. Cook for 20 minutes, then put through a food press and strain juice through cheesecloth. At this point, juice may be frozen until ready for use.

Put cactus juice, lemon juice, and sugar in the 8-quart pan. Mix and place

Jack Lewis

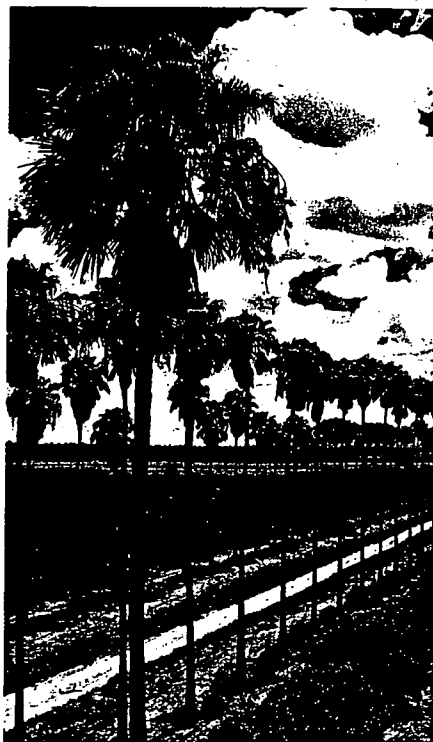

over high heat. Bring to a boil, stirring constantly, then stir in Certo at once and boil hard for 1 minute, continuing to stir. Remove from heat and skim off foam with a metal spoon. Pour into hot, sterilized jars and seal with lids or cover with hot paraffin. Let stand overnight to set.

If you ask five people what to do with the wild elderberry growing along your fence, you may get five different answers, advising you to use it for food, drink, medicine, whistles, or shrubs—and some of those uses will have multiple applications. Elderberry fans range from European artisans to Indian chiefs. The plant itself is a subject of Old World folklore.

In 1985, when writer Howard Peacock explored the various uses, *Texas Highways* dubbed the botanical *Sambucus* "The Incredible Edible Elderberry." Peacock borrowed an elderberry pie recipe from naturalist Bradford Angier and witnessed the cooking of elderberry blossom fritters in the kitchen of Carmine Stahl, executive director of the Houston Audubon Society.

Certainly, Stahl's Elder-Blow Wine changed Peacock's perspective on the *Arsenic and Old Lace* plot, wherein two little old ladies laced the beverage with poison to commit murder. Peacock pointed out, too, that Dr. Alfred Kinsey occasionally put aside his research statistics on sex to concentrate on making chutney and a dessert variation called Elderberry Rob.

If you have a bush with elderberries, you'll probably think of something else.

### *Papa Stahl's Elder Flower Fritters*

2 cups unblemished elder flowers  
1 cup flour  
1 tablespoon sugar  
1 teaspoon baking powder  
2 eggs  
½ cup milk  
cooking oil, at least 1 inch deep in frying pan  
orange juice  
powdered sugar

Pick flowers clean, wash gently in cool water, and drain. Sift together flour, sugar, and baking powder. Beat eggs, add milk, and mix with dry ingredients. Heat oil to 375° F. Mix flowers into batter and drop by tablespoons into hot oil. Brown both sides of fritters, remove, and drain. Sprinkle with orange juice, dust with powdered sugar, and eat them hot.

### *Alfred Kinsey's Elderberry Rob*

2-3 cups dried elderberries  
1 tablespoon cloves  
1 tablespoon nutmeg  
1 tablespoon cinnamon  
½ pound sugar

Boil enough dried berries in water to get 1 quart of juice. Add spices and simmer ½ hour. Strain, and add sugar. Boil for a few minutes, skim, and seal in jars while hot. Poach wild pears in the sauce, or spoon it over other desserts. (Adapted from *M. F. Berry's Fruit Recipes*, published by Doubleday in 1907.)

PATRICIA HOPKINS  
MARCH 1999

TOPS & BOTTOMS  
BY JANET STEVENS  
SCHOLASTIC INC. NEW YORK, 1995

SUMMARY

ALL BEAR WANTED TO DO WAS SLEEP. ONE DAY HIS NEIGHBOR, HARE, OFFERED HIM A BUSINESS DEAL HE COULDN'T RESIST. HARE SAID HE WOULD DO THE HARD WORK OF PLANTING AND HARVESTING THE VEGETABLES AND SPLIT THE PROFIT DOWN THE MIDDLE. FIRST TIME BEAR SAID HE WOULD TAKE THE TOP HALF (OF THE VEGETABLES) AND THEN ACCUSED HARE OF TRICKING HIM WHEN ALL HE GOT WAS A PILE OF CARROT AND RADISH TOPS. CAN YOU PREDICT WHAT BEAR ASKED FOR THE NEXT TIME?

SCIENCE AND CONTENT RELATED CONCEPTS

LEAVES, FLOWERS, ECOLOGY, FOOD GROUPS

CONTENT RELATED WORDS

GERMINATION, PHOTOSYNTHESIS, CHLOROPHYLL, TRANSPIRATION, SEEDS, FLOWERS, LEAVES, STEMS, ROOTS

ACTIVITIES

1. SEEDS AND SEED PARTS.... HAVE A VARIETY OF SEEDS FOR THE STUDENTS TO EXAMINE. HAVE STUDENTS DISCUSS THE ROLL OF SEEDS IN THE LIFE OF A PLANT. GIVE EACH STUDENT A BEAN THAT HAS BEEN SOAKED, A TOOTH PICK, FOOD COLORING AND A HAND LENS. CAREFULLY "PEEL" THE SKIN OFF OF THE BEAN AND SPLIT THE SEED INTO TWO HALVES. ( REPEAT UNTIL A COMPLETE EMBRYO CAN BE SEEN ON ONE HALF OF THE SEED.) DIP THE TOOTH PICK INTO THE FOOD COLORING AND "PAINT" PARTS OF THE EMBRYO. USING THE HAND LENS, IDENTIFY THE EMBRYO LEAVES (PLUMULUS), THE EMBRYO ROOT (RADICLE) AND THE STORED FOOD (COTYLEDON). HAVE THEM DRAW AND LABEL WHAT THEY SEE. POINT OUT THAT PLANT SEEDS CONTAIN THE BEGINNINGS OF A COMPLETELY NEW PLANT., THE EMBRYO ROOT WILL GROW DOWN IN THE SOIL AND THE LEAVES WILL GROW UPWARD TO REACH THE SUNLIGHT. THE REST OF THE SEED IS STORED FOOD THAT THE EMBRYO PLANT USES UNTIL ITS OWN LEAVES REACH THE SUN AND BEGIN MANUFACTURING THEIR OWN FOOD.

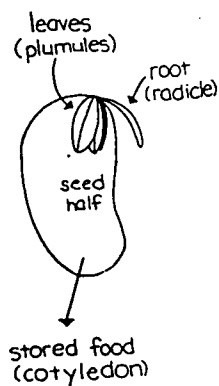

2. GERMINATION.....SOAK PINTO OR LIMA BEANS OVERNIGHT. FOLD DAMP PAPER TOWELS AND PUT IN CLEAR PLASTIC CUPS OR PLASTIC BAGS. PLACE BEAN SEED ABOUT HALF WAY DOWN BETWEEN THE PAPER TOWEL AND THE GLASS OR PLASTIC. KEEP MOIST BUT BE SURE AIR CAN GET IN IF YOU USE PLASTIC BAGS. MARK GROWTH OF STEM AND ROOT EACH DAY ON OUTSIDE. ( THE PLASTIC BAGS CAN BE PUT ON THE BULLETIN BOARD.)

3. PLANT PARTS.....MOST PLANTS HAVE FIVE PARTS IN COMMON; ROOTS, STEMS, LEAVES, FLOWERS AND SEEDS. EACH PART HAS A JOB TO DO IN HELPING A PLANT LIVE AND GROW. MAKE A FLIP BOOK ILLUSTRATING THE PARTS ON THE OUTSIDE THEN DESCRIBING EACH ON THE INSIDE.

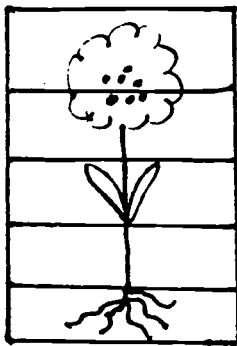

- FLOWERS HOLD THE PARTS OF THE PLANT THAT HELP IT REPRODUCE.
- SEEDS MAKE NEW PLANTS.
- LEAVES MAKE FOOD.
- STEMS CARRY WATER AND MINERALS FROM ROOTS TO LEAVES AND THEY HOLD UP THE PLANT.
- ROOTS HOLD PLANTS IN PLACE AND ALSO TAKE IN WATER AND MINERALS.

4. THINGS NECESSARY FOR HEALTHY PLANTS....GIVE EACH GROUP OF STUDENTS 4 CUPS, 4 SEEDLINGS, POTTING SOIL AND GRAVEL. PLACE GRAVEL IN BOTTOM, ADD SOIL AND PLANT SEEDLINGS. WATER WITH 60ML. MARK THE CUPS A, B, C, AND D. PUT CUPS A & C IN A WARM, SUNLIT SPOT. PUT CUP B UNDER AN OPEN LUNCH SACK IN A WARM SPOT. PLACE CUP D IN AN OPEN ICE CHEST WITH ICE. WATER CUPS A, B, AND D WITH 60ML OF WATER EVERY OTHER DAY. WATER CUP C WITH 30ML OF WATER EVERY OTHER DAY. MEASURE GROWTH OF EACH PLANT WITH A RULER ONCE A WEEK. RECORD DATA FOR EACH PLANT ON PAPER. CONTINUE FOR ONE MONTH. (INCREASE OR DECREASE AMOUNT OF WATER GIVEN BUT GIVE THE SAME AMOUNT.)

5. LIGHT.....TAKE A HOUSEPLANT AND AN OPAQUE BOX THAT IS LARGER THAN YOUR PLANT. POKE A HOLE APPROXIMATELY  $\frac{1}{2}$ " WIDE THROUGH WHAT WILL BE THE TOP. TURN THIS UPSIDE DOWN OVER THE PLANT. THE PLANT WILL LOOK FOR LIGHT, FIND THE HOLE AND POKE ITS STEM RIGHT OUT OF THE CONTAINER.

6. ROOTS.....ROOTS WILL ALWAYS GROW DOWNWARD, EVEN IF THERE'S AN OBSTACLE IN THE WAY. TAKE A SEEDLING, A FLOWERPOT, POTTING SOIL, AND A BLOCK OF WOOD. THE WOOD SHOULD BE PRESSED DOWN IN THE SOIL AND COVERED. THE SEEDLING IS THEN PLANTED IN THE POT ABOUT  $\frac{1}{2}$ " ABOVE THE WOOD. AFTER SEVERAL DAYS, UNCOVER THE SEEDLING CAREFULLY AND OBSERVE HOW ITS ROOTS ARE FORMING AROUND THE WOOD AND CONTINUING DOWN TOWARD THE BOTTOM.

7. STEMS.....PUT APPROXIMATELY 2" OF WATER IN A JAR. COLOR GENEROUSLY WITH FOOD COLORING. CUT A FRESH EDGE AT BOTTOM OF A CELERY TALK. PUT CELERY STALK INTO JAR. OBSERVE COMPLETE STALK HOURLY DURING SCHOOL AND THEN AT THE END OF 24 HOURS. SLICE CELERY STALK CROSSWISE EVERY 2"-3" AND OBSERVE. WHEN YOU CUT THROUGH THE CELERY STALKS YOU CAN SEE THE TINY "PIPES" THAT CARRY WATER UP THE PLANT. THESE "PIPES" ARE CALLED XYLEM. YOU CAN ALSO SEE THAT THE LEAVES ARE THE SAME COLOR AS THE COLORED WATER IN THE JAR.

8. LEAVES....YOU WILL NEED THREE POTTED, NEWLY-SPROUTED PLANTS OF THE SAME SIZE. LABEL THE PLANTS 1, 2, AND 3. PINCH ALL THE LEAVES OFF PLANT 1, HALF OFF PLANT 2 AND NONE OF THE LEAVES OFF OF PLANT 3. WATER AND DRAIN ALL THREE PLANTS THOROUGHLY. PLACE THE PLANTS IN A SUNNY AREA.



EVERY THREE DAYS CHECK, MEASURE, AND WATER THE PLANTS. CONTINUE TO PINCH OFF ALL LEAVES ON #1, HALF FROM #2, AND NONE FROM #3. RECORD THE MEASUREMENT AND THE CONDITION OF EACH PLANT. DISCUSS WITH STUDENTS HOW PLANTS MAKE THEIR FOOD. DEFINE SUCH WORDS AS CHLOROPHYLL AND PHOTOSYNTHESIS.

9. SEEDS AND PLANTS WITHOUT SOIL.....BUY SPROUTING SEEDS AT A GROCERY OR HEALTH FOOD STORE. GROW THE SPROUTS IN CLEAN JARS WITH A CHEESECLOTH LID SECURED BY RUBBER BANDS. SOAK THE SEEDS OVERNIGHT AND DRAIN IN THE MORNING. RINSE AND DRAIN THE SEEDS TWICE DAILY. COVER THE JARS WITH A CLEAN CLOTH TO KEEP OUT THE LIGHT. KEEPING THEM IN A WARM LOCATION SPEEDS UP SPROUTING. REMOVE THE CLOTH AND EXPOSE THE SPROUTS TO SUNLIGHT FOR "GREENING" THE LAST TWO DAYS BEFORE EATING. THEY ARE USUALLY READY IN LESS THAN A WEEK. STUDENTS CAN ALSO OBSERVE HOW SOME PLANTS WILL ROOT AND CONTINUE TO GROW IN WATER.

10. TRANSPIRATION.....HAVE A GOOD SIZE PLANT WITH LOTS OF LEAVES. PLACE A CLEAR PLASTIC BAG OVER A BRANCH OF LEAVES AND SECURE THE BAG WITH A TIE. ON ANOTHER BRANCH COAT THE TOPS OF THE LEAVES WITH PETROLEUM JELLY AND ALSO COVER AND SECURE. ON ANOTHER BRANCH COAT THE BOTTOM OF THE LEAVES AND ALSO COVER. ON A FOURTH BRANCH COAT THE TOP AND THE BOTTOM OF THE LEAVES AND COVER. WHAT WERE THE RESULTS?

11. PLANT PARTS AND VEGETABLES.....HAVE A VARIETY OF VEGETABLES FOR STUDENTS TO OBSERVE...SUGGESTIONS; CABBAGE, LETTUCE, SPINACH, BRUSSELS SPROUTS (LEAVES), ONION, GARLIC (BULBS), CARROT, RADISH, BEETS, TURNIPS (ROOTS), RHUBARB, ASPARAGUS, CELERY (STEMS/STALKS), POTATOES (TUBERS), ARTICHOKE (FLOWER). HAVE STUDENTS OBSERVE THE VEGETABLES. COMPARE AND CONTRAST THEM WITH EACH OTHER. CLASSIFY THE VEGETABLES.

12. EACH STUDENT SHOULD KEEP A PLANT JOURNAL TO RECORD THEIR OBSERVATIONS. THE OBSERVATIONS MAY BE RECORDED IN SENTENCES OR SKETCHES WHICH KEEP TRACK OF CHANGES OBSERVED IN THE PLANTS,

13. A LANGUAGE ARTS ACTIVITY CAN BE TO JOURNAL ABOUT WHAT HAS BEEN LEARNED ABOUT PLANTS. SUGGESTIONS;

\*WHAT IS YOUR FAVORITE PLANT AND WHY?

\*CREATE A SEED-TO-FLOWER-TO SEED STORY USING PICTURES.

\*TELL A STORY ABOUT A PLANT WITHOUT LEAVES.

\*USE WHAT YOU KNOW ABOUT ROOTS TO CREATE AN IMAGINARY PLANT WITH A ROOT SYSTEM THAT COULD SUPPORT IT ..NAME AND COLOR THE PLANT.

\*DRAW A PICTURE SHOWING WHAT A HEALTHY PLANT NEEDS.

\*LIST THE PLANTS (FOODS) YOU WOULD MISS MOST/LEAST.

\*LIST AS MANY USES OF PLANTS AS YOU CAN.

14. CORN IS JUST ONE OF THE MANY PLANTS THAT HAS A WIDE VARIETY OF USES. IT IS A GOOD PRODUCT TO TRACE FROM PRODUCER TO CONSUMER IN SOCIAL STUDIES. THERE ARE MANY CORN RELATED PROJECTS; USES OF CORN, CORN PRODUCTS THAT CONTAIN CORN, THINGS MADE FROM CORN OR THE CORN PLANT.

15. THE STUDY OF PLANTS REQUIRES THE USE OF MATH ORIENTED SKILLS. THE ABILITY TO MEASURE, COMPARE, AND GRAPH ARE JUST A FEW OF THE SKILLS THAT CAN BRING MATHEMATICS INTO YOUR PLANT LESSONS.

1 16. WORD SEARCH....LOOK FOR THESE WORDS; THEY MAY BE RUNNING VERTICALLY, HORIZONTALLY, OR DIAGONALLY.

SPROUT	STEM	RAIN
SOIL	SUN	GERMINATE
LEAVES	LIGHT	SEED
BEAN	WIND	WEED
WATER	ROOTS	FERTILIZER
DRY	BLOOM	WET
WEATHER	ROT	PRUNE
LIMP	BEND	FALL

B	P	E	A	S	S	O	I	L	C	O
L	I	M	P	P	R	U	N	E	U	B
O	N	G	E	R	M	I	N	A	T	E
O	C	A	S	O	I	L	B	V	T	A
M	H	S	A	U	X	I	N	E	I	N
E	W	E	T	T	N	Y	A	S	N	S
W	E	A	T	H	E	R	G	E	G	D
F	E	R	T	I	L	I	Z	E	R	A
A	D	S	O	E	W	I	N	D	N	R
L	A	T	H	O	R	N	G	T	B	A
L	B	E	A	N	T	O	E	H	S	I
R	E	M	D	R	Y	S	T	S	T	N

17. MAKE A MATCH.....

THE SPROUTING OF A SEED IS CALLED  
 PHOTOSYNTHESIS OCCURS MAINLY IN  
 THIS HOLDS THE PLANT IN THE GROUND  
 NECESSARY FOR PHOTOSYNTHESIS  
 CONTAINED IN A SEED  
 TAKEN IN WITH WATER THROUGH THE ROOTS  
 GIVES PLANTS THEIR GREEN COLOR  
 SUPPORTS THE PLANT  
 NEEDED BY PLANTS FOR GROWTH  
 A POTATO IS CALLED A

WATER  
 MINERALS  
 ROOTS  
 STEM  
 SUNLIGHT  
 GERMINATION  
 EMBRYO  
 LEAVES  
 CHLOROPHYLL  
 TUBER

TEKS-2.5A, B, 2.6A, C, 2.7A, 2.8A, 2.9A, B, 2.10B

Gr. 2

Verdi  
By Janell Cannon

New York, NY: Scholastic Incorporated, 1997

Presented by Felicia Trevino  
Teaching Science through Children's Literature  
EDCI 5390  
March 22, 1999

## Verdi by Janell Cannon

### Summary

This is a story about a green tree python named Verdi. He likes being young and mischievous and doesn't want to change into a grumpy, lazy, and mature "green". When he starts turning green (peeling) he tries to prove to everyone including himself that he is as young as ever. Verdi eventually realizes that can mature and still keep his individualism.

### Science and Content Related Concepts

animal life cycles, interactions in a simple system, adaptive characteristics of pythons within their ecosystem, predator/prey characteristics

### TEKS

5.5B, 5.6C, 5.9ABC, 5.10A

### Content Related Words

predator  
venomous  
carnivores

pip

Morelis viridis

suffocate  
egg tooth  
interweave  
prey  
windpipe

camouflage  
fangs  
nonvenomous  
clutch  
Jacobson's organ

## Verdi Activities

1. Before reading Verdi, I would preview what the children know about the story by just looking at the title (a green snake). I would also discuss that these green tree pythons live in tropical habitats, such as rainforests. I would review the types of animals that live in the rainforest, specifically snakes. I would also do a KWL on snakes, because like bats there are many misconceptions about snakes and their benefits.

### 2. Camouflage Activity

This AIMS activity demonstrates how animals protect themselves from predators because of their ability to blend into their surroundings. Punch out at least ten holes of the following colors: yellow, green, black, pink. Procedure: Divide up the class into groups of two. Give each group a sheet of yellow, green, black, and pink; this is their background paper. One person will be the timekeeper and the other will be the observer. The activity calls for the students to be at least two meters from the background construction paper. The timekeeper places the paper on the floor and dumps the punched holes on the paper and times for 10 seconds the number of prey counted by the observer. Then, the partners switch jobs until all of the backgrounds have been covered. Record your findings.

### 3. Predator vs. Prey Activity

This AIMS activity also demonstrates the importance of protective coloring. The objective of this activity is to show how predators will be able to find some prey, however, other will survive depending on its ability to blend itself into its surroundings. Divide your students into two different groups and have one group wait outside. The other groups needs to find good hiding places around the room to hide his/her pieces of pipe cleaners. When the “prey” are done hiding then the “predators” have to come back in the room and find their food. The predators only have 30 seconds to find the prey. After their time is up,

## Verdi Activities

the observation sheets need to be filled out. The pipe cleaners that are not found are considered to be survived. The pipe cleaners found are dead.

### 4. Snake Skin Activity

This activity is very messy and fun for the students. What you need to do this activity are: long-shaped balloons, Elmer's Glue, twine, and scissors. First, you get the children to blow up the balloons, emphasizing that the longer you make it the harder it will be cover the balloon. I would limit the "snake size" from 6" to 8". Then, the hard part.. getting the winding of the twine started. For the younger ones, I would get them started, or have them in groups of two because their hand coordination is crucial. Then, the students wind up the twine placing the glue on the balloon first and then following the twine with their fingers around the balloon.

### 5. Interweaving Activity

This activity will show the students how the snake's coloration is made. It shows how all the different colors come together to form a combination of colors. Make copies of the lined paper and the zigzagged slits on different, bright-colored paper or cardstock. Cut as instructed and weave the strips of paper into the zigzagged paper. Make a cylinder out of the paper to make it look like a snake shape.

### 6. Verdi Trifold

Using Dinah Zike's instructions for making a trifold have the students depict their favorite scenes from the story and illustrate and caption 4 scenes. This would be great to show during open house or "hallway" work.

## Verdi Activities

### 7. Food Web

In *Verdi*, there are many webs of food demonstrated during the story. For example, the catfish wanted to eat Verdi, but Verdi escaped. The greens discuss how long it took to digest a lizard. As a class, discuss the interdependence within Verdi's habitat. Also emphasize that snakes may be scary, but they do play an important role in the rodent population. Without snakes, the rodent population would increase.

### 8. Swallowing Prey

The process in which snakes kill and devour their prey is very interesting to students, especially to fifth graders. Discuss and show how the snakes have certain characteristics to make swallowing prey easier. The constrictors also do not "strangle" their prey. Snakes tighten themselves around their prey each time the prey exhales, which doesn't allow the prey to breathe back in. This action suffocates them.

### 9. *Verdi* Crossword

After discussing snakes, the following crossword would serve as a good review. Some of these words are antonyms, but most of these words are body parts and snake characteristics.

### 10. I have, who has

This is another cumulating activity for the unit. Using the content related words, make a batch for the snake vocabulary. Any student can start, but everyone has to be listening, because no one knows the order of the cycle. Students have to be listening for this activity to go smoothly.

# NOW YOU SEE IT, NOW YOU DON'T

## I. Topic Area

Natural selection and camouflage.

## II. Introductory Statement

Students will investigate how some animals may have greater protection from their enemies (natural selection) because of their ability to blend into their surroundings.

## III. Math Skills

- Whole Number Operations
- Percent

## Science Processes

- Observing
- Collecting Data
- Analyzing Data

## IV. Materials

1 sheet 22" X 28" railroad or poster board in each of these four colors: black, yellow, green, or pink (or your favorite choice)

Paper cutter or sharp scissors

Standard hole punch

Strong bench, table, or step ladder

## V. Key Question

Does an animal that blends into its environment have a better chance of surviving from its predators than otherwise?

## VI. Background Information

We know that certain organisms with certain traits have a better chance of surviving and reproducing. Charles Darwin called this "survival of the fittest". Those organisms that survive and reproduce, pass on the traits to their offspring that will enable them to survive. Through this natural selection process only the organisms that are best suited to their environment survive.

One of these natural selection adaptations is the coloration of an animal. Certain insects, birds, reptiles, and land animals have natural color patterns that enable them to blend into their environments. Some examples are polar bears, deer, chameleons, meadow larks, pheasant, frogfish, pipefish, treehoppers, and dead leaf mantis. This special coloration has enabled each animal to survive.

## VIII. Procedure

- With a paper cutter, take a one inch strip off the length of each of the four pieces of colored tag-board. Use a paper punch and punch out 50 disks of each color.
- Place one of the large pieces of colored board on the floor and spread 50 disks of each color over the board as evenly as possible.
- There are three student functions: the counter, the safety man, and the timer-recorder.

The experiment requires that the student-counter stand a minimum of two meters above the railroad board with the disks on the floor. The student-counter will be given ten seconds to count silently as many of the disks as he can see during that time limit. He counts them in succession, as indicated on Chart I. It is emphasized that the student-counter must stand at least two meters above the "field of prey" in order for the experiment to work effectively.

The safety man makes sure that the student-counter does not fall off the bench, ladder, or whatever you use to maintain the proper height from the "field of prey". He may also ensure that the student-counter does not continue to scan the "field of prey" after the timer-recorder tells him to stop.

The timer-recorder obviously works the time-clock for the ten second count and then he records on Chart I the number of disks spotted by the student-counter on each attempt. The three students rotate until each has completed all three tasks.

Scenario: Tom (student-recorder) is standing upon a sturdy and strong chair above the railroad board ("field of prey"), but he is looking away from the "field of prey". John (safety man) is watching Tom to ensure he doesn't fall and that he doesn't look down on the "field of prey" until Norris (timer-recorder) tells him to start. Norris tells Tom, "Count the yellow disks when I say 'go'". Norris says "go" and Tom begins to count the yellow disks until Norris says "stop". Tom stops, looks away from the "field of prey", tells Norris the number of yellow disks he counted, and Norris records that number on Chart I. Norris then says, "Count the green disks when I say 'go'". Etc., etc.



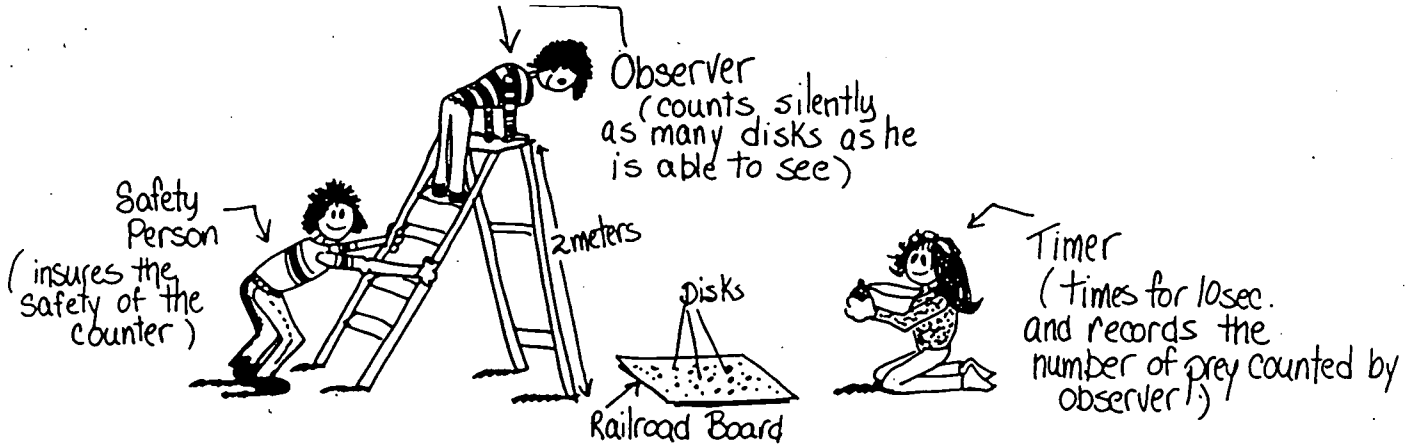

- Once the data has been collected each student determines the percentage of disks counted on each attempt. The pattern should become obvious that the number of the same colored disks counted should be substantially lower than the different colored disks counted.

#### X. Discussion

- Does the color of the background make a difference in the number of the disks, by color, that were counted? Why do you think this happened?
- Did you know that the disks were supposed to be small animals living on the ground? Did you know that counting the disks during each trial was supposed to be a larger animal feeding on a smaller animal?
- Can you see by the total of your results that the protection of blending with the background does help "disk animals" survive?
- Does an animal that does blend into its background have a better chance of surviving? Might this be an example of natural selection?
- Can you name some animals where the natural selection process might be at work? (You might have each student submit a report on an animal exhibiting some form of the natural selection process.)

If you do not wish to provide so much "leadership" in helping the students understand the natural selection concept you might simply ask the following questions:

- What happened?
- Why do you think this happened?
- How might this relate to the survival of some species in our world?

#### XI. Extension

Variation: "Birds and Worms"

This simulation game is great for an outdoor experiment.

#### Materials

Green, red, blue, yellow and brown pipe cleaners.  
Cut each pipe cleaner into thirds — bend into "worms".  
Butcher paper (large sheets — 1 meter square)

#### Procedure

- Scatter the "worms" in a specified area, in the grass, on the ground, etc.
- Give the students names of birds (Robin, Thrush, Meadowlark, Bluebird, Flicker, Crow, etc).
- One at a time call out the name of the bird. As each species is called, the "bird" (student), can "fly" out over the area where the worms were scattered and pick up the worm that first catches the "birds" eye.
- As the birds return have them lay out the worms on the butcher paper in the order in which they were picked up.
- Repeat this process until all the birds have had a chance to fly over the area.
- Have the students consider the color sequence of the worms captured and placed on the paper.

#### Discussion

- What trends or patterns appeared? (If the worms were scattered on grass, one would expect the "green worms" to be picked up at the end of the simulation game, rather than in the early flights.)
- Is there any relationship between coloration and the usual habitat of the worms?
- Might there be similar relationships for other animals?
- What is the value of animal coloration?
- Did it take the last birds to fly out a longer period of time to find their worms? What implications might this have towards survival of both the worms and the birds?

# ANIMAL CAMOUFLAGE

NOW  
YOU  
SEE

IT,  
NOW  
YOU

DOUBT

Color of Disks	Yellow Background
	# Counted
	% Counted
YELLOW	
GREEN	
BLACK	
PINK	

Color of Disks	Black Background
	# Counted
	% Counted
BLACK	
PINK	
YELLOW	
GREEN	

Color of Disks	Green Background
	# Counted
	% Counted
GREEN	
BLACK	
PINK	
YELLOW	

Color of Disks	Pink Background
	# Counted
	% Counted
PINK	
YELLOW	
GREEN	
BLACK	



1. What happened?  
2. Why do you think this happened?  
3. How might this relate to the survival of species in our world?

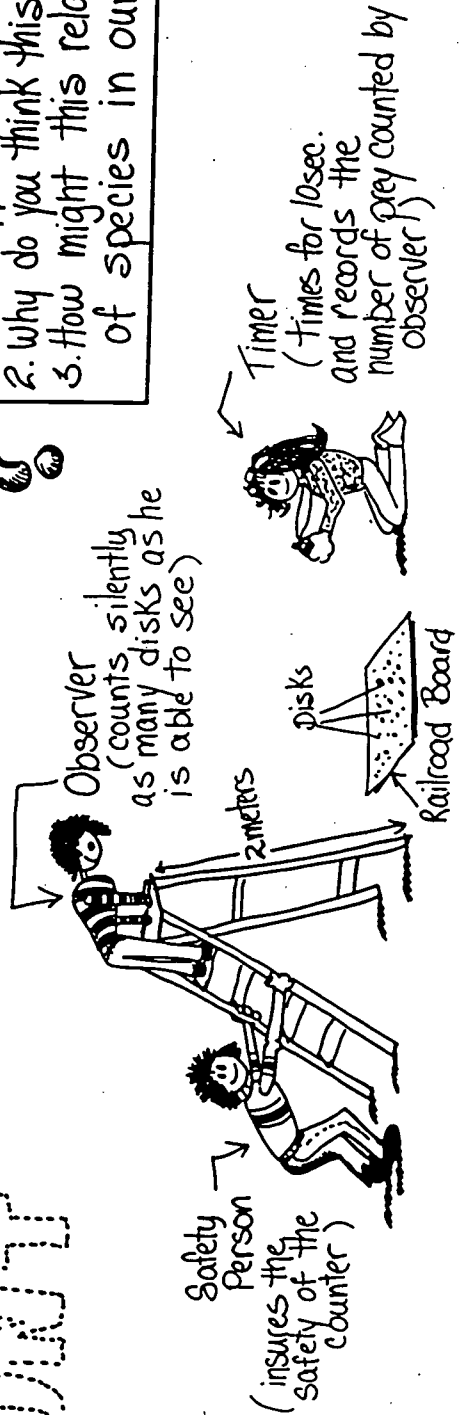

# PREDATOR vs. PREY

## I. Topic Area

Protective coloration and animal survival

## II. Introductory Statement

Students will learn the importance of protective coloring and how animals use their senses.

## III. Math Skills

- Graphing
- Averaging

## Science Processes

- Collecting & Organizing Data
- Making Inferences
- Observing

## IV. Materials

Various colored pipe cleaners  
Blindfold

## V. Key Question

How does protective coloration contribute to the survival of animals in the predator-prey relationship.

## VI. Background Information

In nature we think of two basic types of animals. Those that eat plants (herbivores) and those that eat other animals (carnivores). Animals whose survival depends on locating and capturing other animals must have highly developed senses, especially that of hearing and smelling. Animals which are the determined prey have a variety of assets to help their survival. Perhaps the greatest of these is their natural coloration which helps them blend into their surroundings. Animals that are not easily seen have greater chance of escaping detection and capture. Those animals which can best survive will pass on these protective devices to their young. This process of natural selection produces an animal who is ideally suited to his environment.

## VIII. Procedure

1. Mark off a small area (size depends on number of students) in which to hide your animals (colored pipecleaners). Explain to the students that they are now predators who have to find their prey. Give the students 30 seconds to find all the food they can and bring it back to you. Chart how many of each color was returned.

	GREEN	WHITE	BLACK	ORANGE	BROWN	RED	YELLOW
Beginning number	10	10	10	10	10	10	10
Number returned	6	3	4	10	2	8	10
Difference (Survival)	4	7	6	0	8	2	0

## X. Discussion

1. What color was most frequently brought back?
2. If you were the prey, what color would you like to be?
3. What are some types of animals we might see in the forest that are orange? green? brown? etc.
4. Why do you think that we do not find many brightly colored animals in the forest?

## XI. Extension

Students stand in a circle. One person is selected to be prey. Another student is selected to be the predator. The predator is blindfolded so that he must rely on his senses to catch his dinner. Both predator and prey are released within the standing circle and a chase ensues. Both "animals" must stay within the circle. Students in the outer ring must be quiet so all the senses can be sharpened. They are also responsible for the safety of the blindfolded predator. When the predator approaches the outer circle, students are to reach out and "touch" him so that he knows his limits. Time span for each pair should be determined by the supervisor.

Note: Try to select an area that is relatively flat and free from obstacles.

### Discussion Questions:

- A. Who was the most effective predator? Why? What type of movement pattern did he use?
- B. Who was the most effective prey? Why? What techniques can prey animals use to survive?
- C. How much was luck involved on the part of both animals?
- D. Summarize the factors that determine successful survival.



BEST COPY AVAILABLE

# PREDATOR vs. PREY

PREDATOR

Hide your animals (colored pipe cleaners) in a marked-off area. Students are now transformed into "predators" who have to find their "prey". Predators have 30 seconds to find all the food they can and bring it back to their starting point. Record how many were returned to find how much of the "prey" survived. Find the average survived and graph.

	COLORS						
	GREEN	WHITE	BLACK	ORANGE	BROWN	RED	YELLOW
	10	10	10	10	10	10	10
TRIAL 1	# Began with						
	# Returned						
	# Survived (difference)						
TRIAL 2	# Returned						
	# Survived						
TRIAL 3	# Returned						
	# Survived						

AVERAGE # SURVIVED

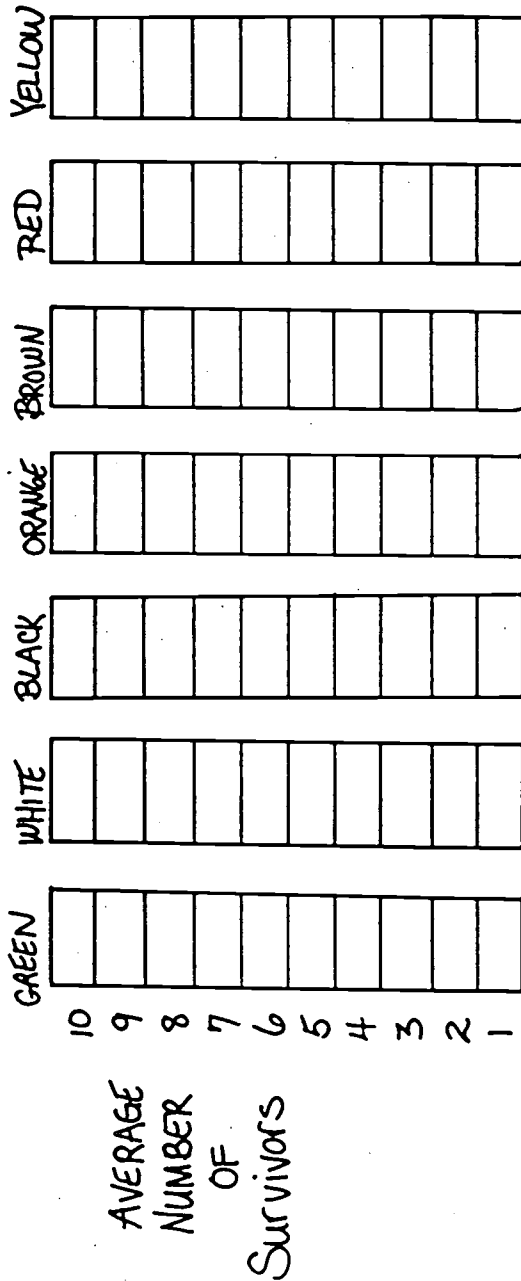

# Weaving Into Zigzagged Slits

Do not cut beyond this line

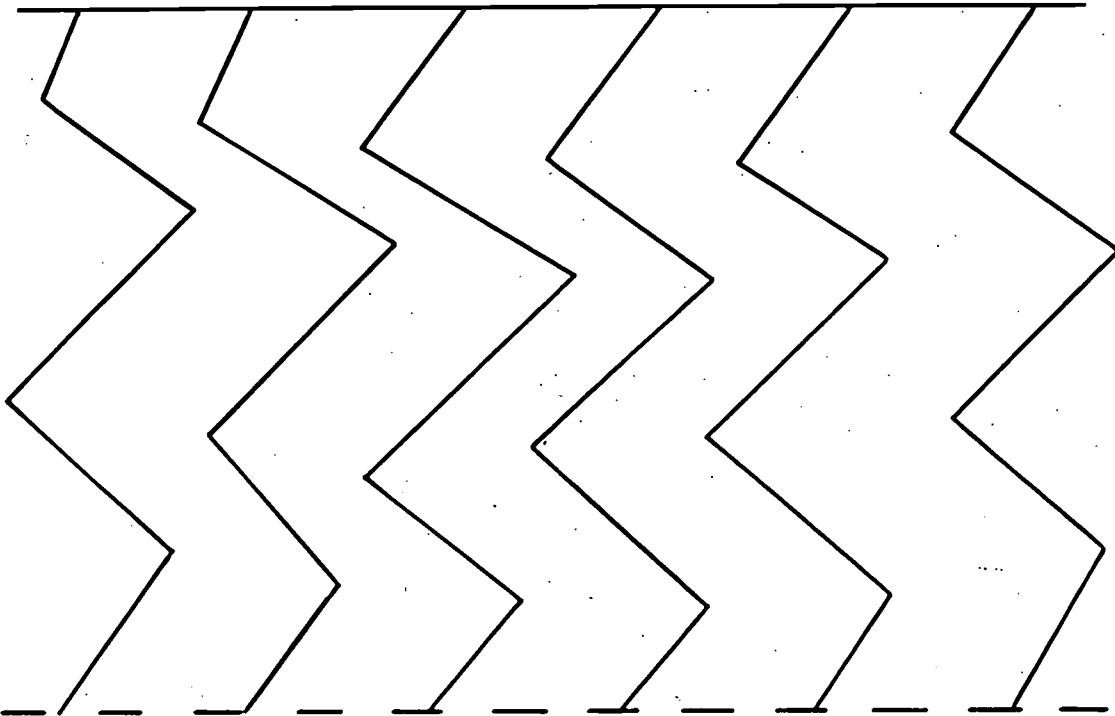



# PYRAMID PATTERN

1. Fold a sheet of paper (8 1/2" x 11") into a taco forming a square. Cut off the excess tab formed by the fold.

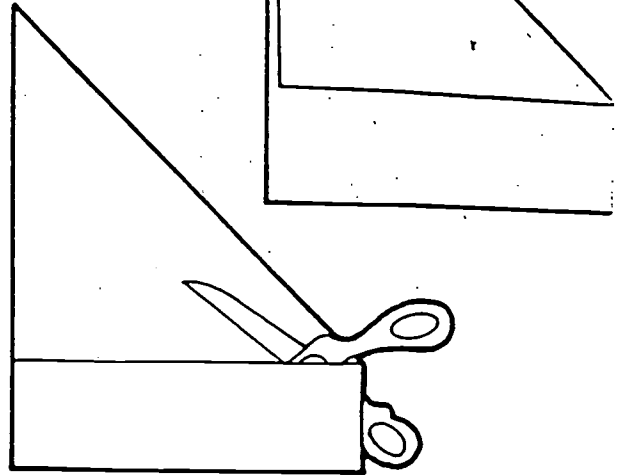

2. Open the folded taco and refold it the opposite way forming another taco and an X fold pattern.

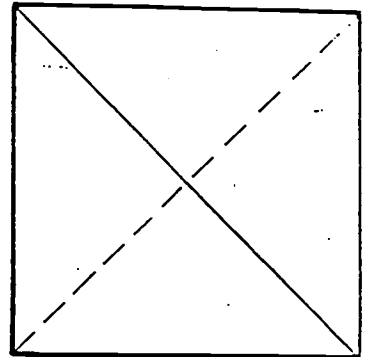

3. Cut up one of the folds to the center of the X and stop. This forms two triangular shaped flaps.

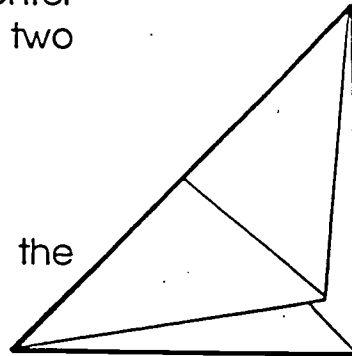

4. Glue one of the flaps under the other flap forming a pyramid.

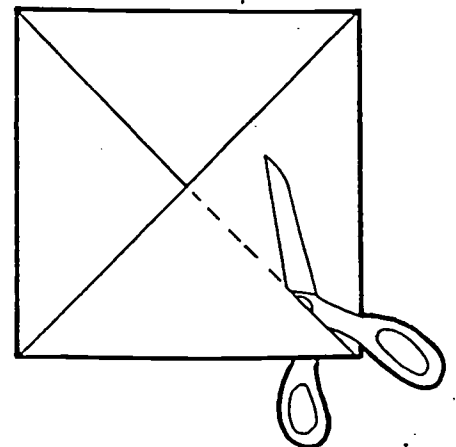
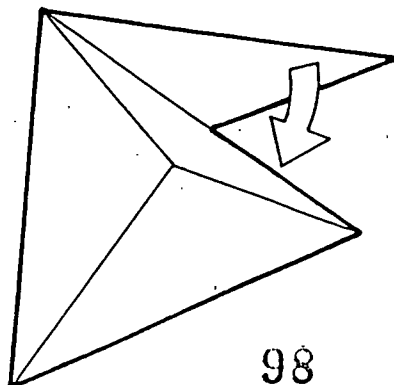
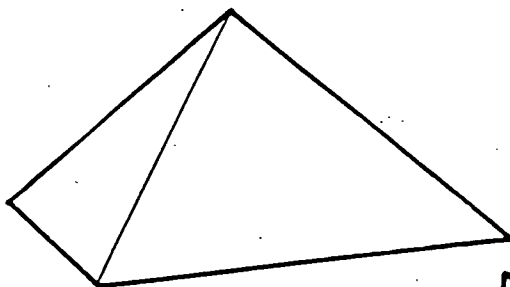

# PYRAMID PATTERN

Pyramids are perfect for illustrating information that occurs in 3's. For example:

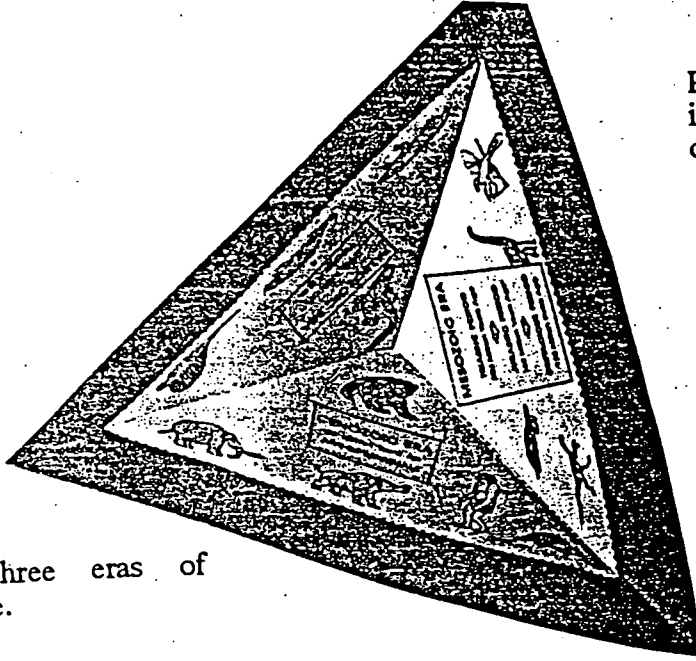

There are three eras of geological time.

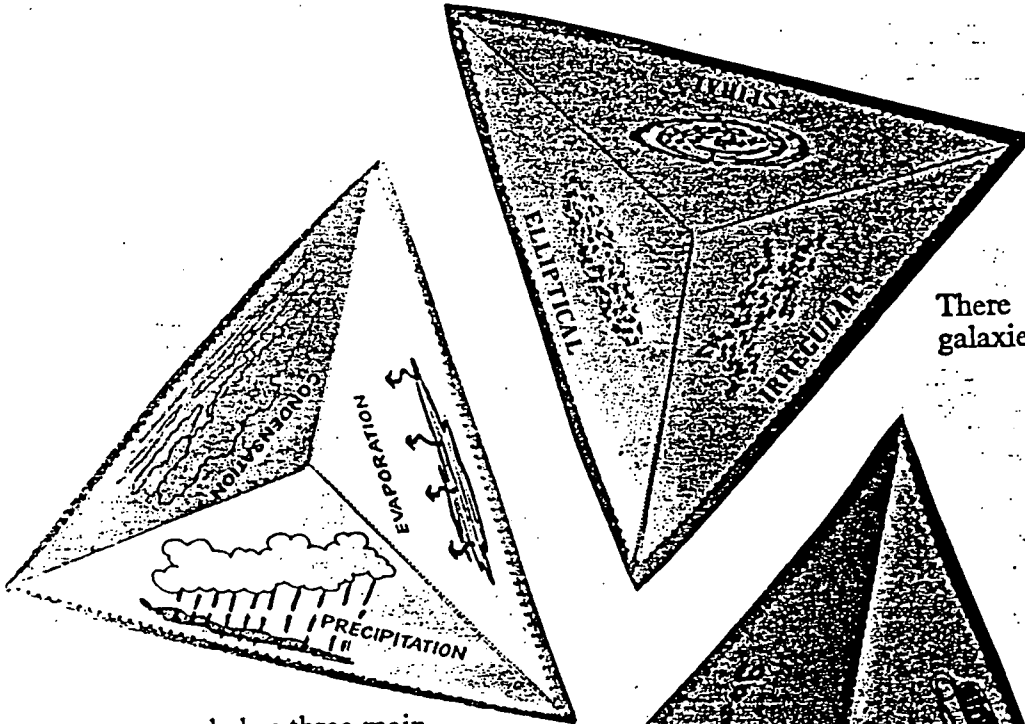

There are three types of galaxies.

The water cycle has three main phases.

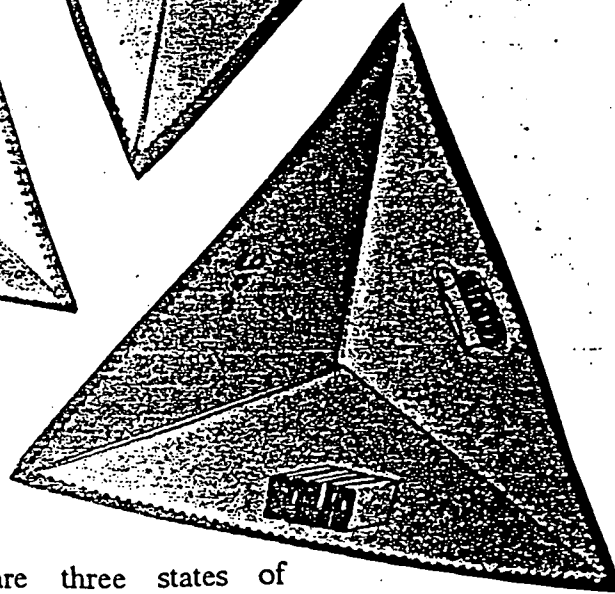

There are three states of matter.



## Verdi Crossword Puzzle

### Across

1. a group of snake eggs
2. an animal hunted or killed by another animal for food.
3. to kill by not allowing an animal to breathe.
4. the first opening made by an animal hatching from an egg
5. temporary tiny ridge which is very sharp and used to open the egg
6. the scientific name for green tree python.
7. venomous snakes have these; nonvenomous snakes do not.
8. these snakes are not poisonous
9. lines of color that cross over each other

### Down

1. meat-eaters
10. these snakes are poisonous
11. the color of the animal's skin that matches the ground around it.
12. on the roof of a snake's mouth; senses prey
13. an animal that kills another animal for food.
14. located on the bottom of the snake's mouth; used during digestion to breathe while swallowing its prey.

### Word Bank

predator  
venomous  
carnivores  
pip

Morelis viridis

suffocate  
egg tooth  
interweave  
prey  
windpipe

camouflage  
fangs  
nonvenomous  
clutch  
Jacobson's organ

# Verdi Crossword

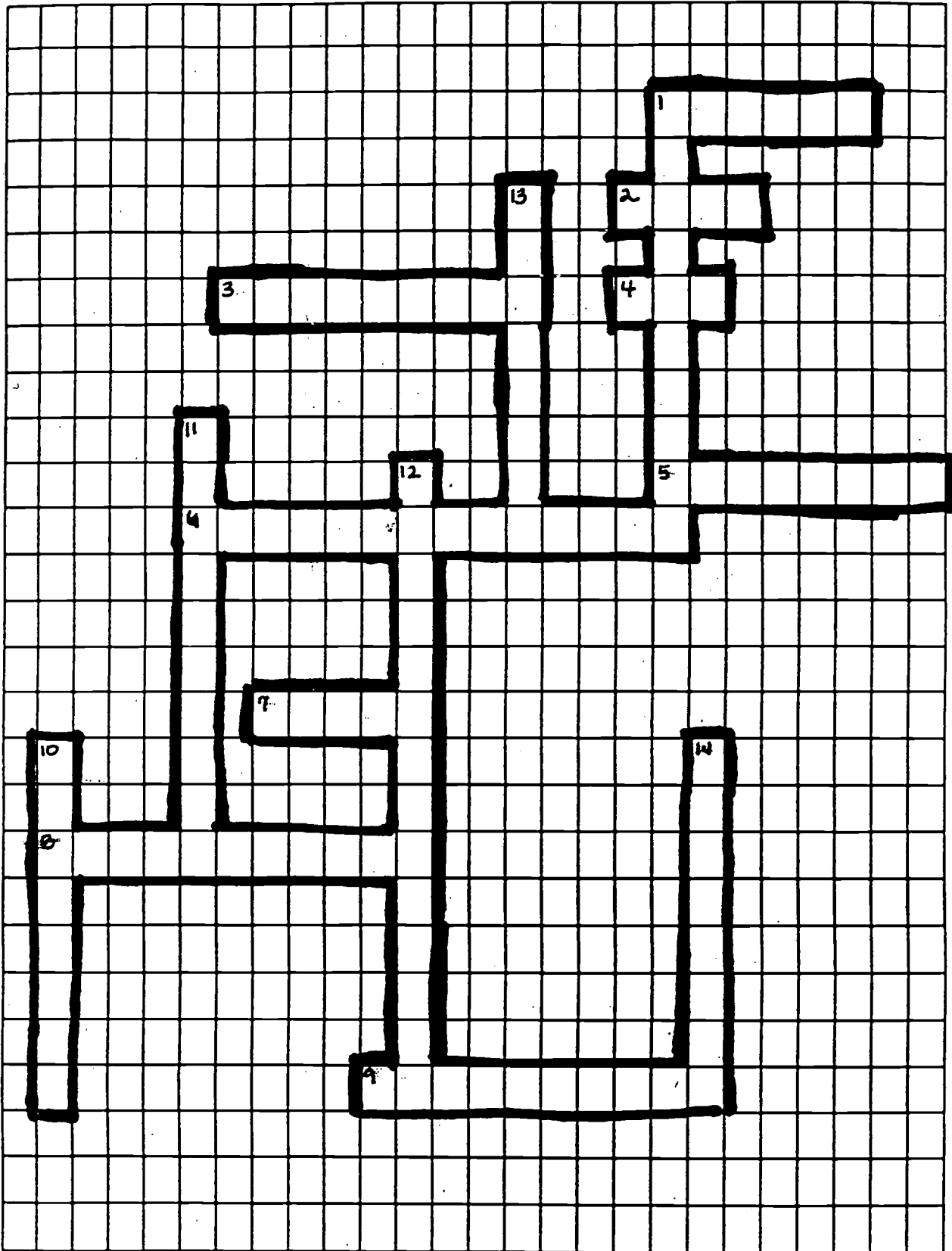

I HAVE...

WHO HAS...

I HAVE...

WHO HAS...

I HAVE...

WHO HAS...

I HAVE...

WHO HAS...

I HAVE...

WHO HAS...

I HAVE...

WHO HAS...

I HAVE...

WHO HAS...

I HAVE...

WHO HAS...

**The States of Matter, and Seasons**

***Spring Snowman***

**by Jill Barnes**

Ada Oklahoma: Garrett Educational Corporation: 1990

**Susan Bice**

**March 8, 1999**

## Summary

The *Spring Snowman* begins with a Snowman sitting high up in the mountains on a Winter day. The next scene shows some animals running down the mountain, and the snowman asking them where they were going and they say down the mountain to the valley because it is Spring. The snowman does not know about Spring, but he soon finds out.

## RELATED CONCEPTS

Water cycle, weather, seasons, and states of matter,

## TEKS

- 1.7 (B) Identify and test ways that heat may cause change such as when ice melts.
- 1.7 (C) Observe and record changes in weather from day to day and over seasons.
- 2.7 (D) Observe, Measure, and record changes in weather, the night sky, and seasons.
- 2.10 (A) Describe and illustrate the water cycle.
- 3.7 (A) Gather information including temperature, magnetism, hardness, and mass using appropriate tools to identify physical properties of matter.
- 3.7 (B) Identify matter as liquids, solids, and gases.
- 4.7 (A) Observe and record changes in the states of matter caused by the addition or reduction of heat..
- 4.7 (B) Conduct tests, compare data, and draw conclusion about physical properties of matter including states of matter, conduction, density, and buoyancy.
- 4.10 (A) Identify and observe effects of events that require time for changes to be noticeable including growth, erosion, dissolving, weather, and flow.
- 4.11 (C) Identify the Sun as the major source of energy for the Earth and understand its role in the growth of plants, in the creation of wind, and in the water cycle.
- 5.6 (B) Identify the significance of the water cycle.
- 5.7 (C) Identify changes that can occur in the physical properties of the ingredients of solutions such as dissolving sugar in water.

# Activities

1. The Water Cycle — Grades 2 - 4
2. I C E (Ice Cream Experiments) lesson — Grades 3 -5
3. Structure of Matter — Grade 5
4. Crystals — Grade 4
5. Matter and Heat — Grades 1-3
6. Water Magic — Grades k - 4
7. Diffusion of Molecules — Grades 3 - 4
8. Molecules and Temperature — Primary Grades
9. Superballs — Grades 4 - 6
10. The Motion of Molecules in Water — Grade 4 - 7

**Academy Curricular Exchange  
Columbia Education Center  
Science**

---

**TITLE:** The Water Cycle

**AUTHOR:** Vilia Natchez, Our Lady of the Snows School,  
Reno, Nevada

**GRADE LEVEL:** Appropriate for grades 2-4

**OVERVIEW:** The water cycle explains the sun heating the earth's surface water so that it evaporates. This vapor gathers in clouds which rise to the cold air. When those clouds become too heavy to float, they release their moisture as precipitation. The precipitation collects in lakes or oceans after siphoning through soil or running down rivers. It then evaporates and repeats the cycle once again.

**OBJECTIVE(s):** Students will be able to:

1. Explain how the water cycle recycles the earth's water supply.
2. Make use of the knowledge of landforms learned in social studies.
3. Form a hypothesis on how/why the water cycle works.
4. Use language arts skills of writing and drawing to explain how the cycle works.

**RESOURCES/MATERIALS:**

Assemble these materials:

soil  
water  
small margarine bowl  
large, clear plastic container or an old aquarium  
plastic wrap  
plastic trees, animals, boat, etc. are optional  
tape or large elastic band  
bag of ice (optional)  
heat lamp (optional)

**ACTIVITIES AND PROCEDURES:**

1. Arrange the soil in the container to make mountains, plateaus, hills, etc., and a lake basin. Place the margarine bowl in the lake basin. Fill the bowl with water. The plastic toys may be added to appeal to the children's imaginations. Cover the container tightly with plastic wrap and secure it by means of tape or the band.
2. Discuss what is expected to happen in the container.
3. Depending on the amount of sun, the project may take 1-3 days. In order to speed the process, a bag of ice may be placed on one end of the covered container, while a heat lamp is focused on the other.
4. Watch for condensation on the plastic "sky" of the container. When enough moisture collects, it will fall onto the landforms as precipitation.
5. Compare the hypothesis to actual results by discussion.

6. Encourage the students to draw the water cycle using arrows to show the flow.
7. Ask the students to write a paragraph explaining their picture. A word bank might be used if needed. Possible words for the bank are: condenses (cools), vapor, clouds, evaporate, precipitation (rain/snow), heavy, soil, oceans, lakes. Try to elicit these words from the students.

---

[Click here](#) to return to OFCN's Academy Curricular Exchange

[Click here](#) to return to OFCN's Academy

[Click here](#) to return to OFCN's Main Menu

---

*John Kurilec*[jnk@ofcn.org](mailto:jnk@ofcn.org)



Home

Lesson Plans

Humor

Ask AC

Teacher Inquiry

Urban Education

Web Wizardry

Links

## ICE (Ice Cream Experiments) lesson

by Norman Brooks

For the first session, students will be given ingredients and instructions for making ice cream. In subsequent sessions they will bring other ingredients to create new flavors, improve on recipes, and improve the quality of their ice cream. As the quality improves, they will want to be able to replicate or produce it consistently. This will require accurate measurements.

### Text Links:

[Home](#)

[Lesson Plans](#)

[Humor](#)

[Ask AC](#)

[Teacher Inquiry](#)

[Urban Education](#)

[Web Wizardry](#)

[Links](#)

All material is my personal opinion, and not that of any other organization. Copyright 1996, 1997 and 1998. Permission is granted for individual teacher use. All rights reserved.

Feedback is invited.



### OBJECTIVES:

The Beauty of this lesson is that it can be used to reach so many objectives. It is most often used as an activity to teach, give practice, or to assess students' knowledge of dealing with variables. It also offers exposure to the experimental process, forms of matter, changing forms of matter and many other science concepts and processes.

### INGREDIENTS and MATERIALS:

(For a class of 30 students who work in pairs.)

- 2-4 bags of party ice
- 1 gallon whole milk
- ice chest
- 1 box rock salt
- 8 oz paper cups (36)
- 5 lbs. sugar
- 1 gallon zip lock bags (15)
- vanilla extract
- plastic spoons (36)
- 1 quart zip lock bags (15)
- paper towels
- two trash cans

Email me!

- two trash cans
- Medicine droppers for extract
- plastic scoops for ice/salt

Trash cans are for disposal of bags, spoons, and cups. Teachers can decide which to recycle. Doing this activity outside simplifies clean up.

### **PROCEDURE:**

1. Combine Sugar (2-4 tablespoons), Extract ( a few drops), Milk 8 oz. per pair) , in small zip lock bag and zip it up. This is the **S E M bag**
2. Combine ice ( 2 cups) and rock salt ( 1/2 cup), in large zip lock bag. **This is the S I bag**
3. Insert **S E M bag** inside the **S I bag** and zip it up.
4. Each partner takes one end of the **S I bag** and the two shake until ice cream is firm.
5. Cups and spoons are then distributed to students for taste testing and eating.

### **VARIABLES**

All ingredients and supplies are **VARIABLES** and can be varied. The students should be encouraged to experiment by changing variables for different results. To conduct an effective experiment, they should only change one variable at a time, and should keep accurate records of what they have done, and what the results were.

### **SOME EXAMPLES OF LESSON EXTENSIONS:**

- Rubrics for judging results
- History of ice cream
- Different flavors
- Fractions and proportions
- Improving appearance
- Ice cream in different cultures
- What's in commercial ice cream?
- How much fat is in ice creams?

- Changing the consistency
- Economics ( costs)
- Following directions
- Working in pairs
- Changing forms of matter
- Why salt?

As you develop new extensions, procedures or ideas for improving this activity, please forward them to Norman Brooks:

LITES-Mills College

5000 Mac Arthur Blvd.

Oakland, CA 94613

Fax: 510-430-3379

or email to: [normanb495@aol.com](mailto:normanb495@aol.com)

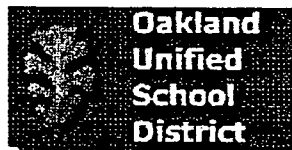
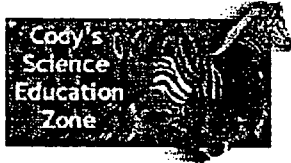

All material on this site is the personal opinion of the author(s) and not that of any organization.  
Copyright 1997 and 1998.

Send your feedback to [Anthony Cody](mailto:Anthony.Cody)

**Academy Curricular Exchange  
Columbia Education Center  
Science**

---

TITLE:           Structure of Matter

AUTHOR:        Linda Smith; Shedeck Elementary, Yukon, OK

GRADE LEVEL/SUBJECT: 5th / Structure of Matter including Mixtures in Science.

OVERVIEW: As a veteran science teacher, I have always found the structure of matter to be the most difficult lessons to make exciting. Although students do not have difficulty learning the terms that describe the structure of matter, they do have difficulty understanding how these concepts relate to their lives. They cannot grasp why reasonable people believe in unseen atoms.

PURPOSE: An understanding of the structure of matter is the gateway to the understanding of the natural universe. Although there are really few practical reasons for understanding the structure of matter, perhaps the most important reason to learn this material concerns students' future decisions on public issues related to energy and waste.

OBJECTIVES: (Note that this is the third of three lessons in this particular unit) Students will learn about mixtures, including solutions and suspensions.

RESOURCES/MATERIALS: Fruit, party mix, drink mix, brownie mix, egg, water, and oil

RESOURCES: Discussion of mixture

ACTIVITIES AND PROCEDURES: Beginning activity-(Students are grouped) Group A is given a variety of fruits and told to make a mixture; Group B is given a bowl of party mix and told to separate items; Group C is given a variety of drink mixes and told to make mixtures; Group D is given ingredients to brownies and told to make a mixture.

TYING IT ALL TOGETHER: After groups have completed their activity, a discussion of results is held, lesson from book is taught. The culminating activity is done on the different types of mixtures (suspension and solution) using water and a variety of items such as sugar, salt, oil, flour, talcum powder etc. Mixing items in cups of water observing reactions.

---

[Click here to return to OFCN's Academy Curricular Exchange](#)

[Click here to return to OFCN's Academy](#)  
[Click here to return to OFCN's Main Menu](#)

**BEST COPY AVAILABLE**

4

**Academy Curricular Exchange  
Columbia Education Center  
Science**

---

**TITLE:** CRYSTALS

**AUTHOR:** Charles Gutierrez, Sierra Vista Elementary, NM

**OVERVIEW:** This lesson is introduced as a supplemental study of matter, chemistry, or as a fun activity for follow up on matter.

**GRADE LEVEL/SUBJECT:** 4th, science

**PURPOSE:** The purpose of this lesson is to introduce the student to the effects of the mixture of different components and also the effect of one chemical on another.

**OBJECTIVE:** The objective of the lesson is that the child will form crystals in the classroom and understand the cause and effect of mixing different chemicals.

**RESOURCES/MATERIALS:**

1 glass slide  
1 test tube  
1 dropper  
1 bottle of mucilage glue  
magnesium sulfate

**ACTIVITIES AND PROCEDURES:**

- 1) put 3 ml of water into the test tube
- 2) add enough magnesium sulfate to make saturated solution
- 3) add a drop of glue, and stir until the glue is dissolved
- 4) using the dropper, put enough of the solution on the glass slide to cover it completely
- 5) wait a few minutes and the child will see the crystals start to form.
- 6) place the glass slide on the window sill and allow to dry

**TYING IT ALL TOGETHER:** This is a good beginning experiment for the fourth grade. It is also possible to make silver crystals using silver nitrate rather than magnesium sulfate but a word of caution when using silver nitrate. Silver nitrate is not to be swallowed or to come in contact with the eyes, so be very careful.

---

[Click here](#) to return to OFCN's Academy Curricular Exchange

[Click here](#) to return to OFCN's Academy

[Click here](#) to return to OFCN's Main Menu

---

*John Kurilec*[mk@ofcn.org](mailto:mk@ofcn.org)

**BEST COPY AVAILABLE**

5

**Academy Curricular Exchange  
Columbia Education Center  
Science**

---

**TITLE:** Matter and Heat

**AUTHOR:** DEBORAH HERNDON, IXL ELEMENTARY SCHOOL,  
ARKANSAS CITY, KS

**GRADE LEVEL/SUBJECT:** GRADES 1-3

**OVERVIEW:** Young students have a difficult time conceptualizing many science concepts. They have a need to actively participate in learning, and even then may not comprehend why an event occurs. One such concept is the motion of molecules and the relationship of heat to states of matter.

**PURPOSE:** To involve students in demonstrating the relationship between molecules and states of matter.

**OBJECTIVES:** As a result of this activity, the students will:

1. Predict that heating a substance will cause it to expand (get big), and cooling it will cause it to contract (shrink).
2. Demonstrate an understanding of solids, liquids, and gases by their activity level as they act like molecules.
3. List examples of solids, liquids, and gases in their world.

**RESOURCES/MATERIALS:**

An additional adult or two is very helpful for the small group experiment. Another management technique could be to allow students to make mosaic pictures of their own while the teacher works with one small group at a time.

1. "Mosaic" picture made from paper punches, microscopes (30X), and various items to observe such as cloth, workbooks, leaves, etc.
2. Materials for the experiment as listed.
3. String for a circle.
4. No materials needed.

**ACTIVITIES AND PROCEDURES:**

1. Introduction

-Discuss the concept that everything is made up of molecules. Show them a "mosaic picture" made up ahead of time from paper punches. This is a simplified exaggeration of something being made up of little things.

-Encourage them to look at several items with hand-held microscopes (30x). Cloth, colors on covers of workbooks, and leaves are good for viewing small parts that are invisible to the eye. Emphasize that they are still not seeing molecules, which are even tinier than each dot they see on the book cover.

2. Small group experiment

Materials needed (for each group)- small flask or bottle, two bowls, balloon, ice, hot water (from a coffee pot is best, but you need to supervise this as it will burn)

Procedure-

- Put the balloon on the bottle. Have students establish that the bottle has air in it and that the air molecules inside cannot get out of the bottle when the balloon is on it.
- Ask students if they think the balloon will change if we put the bottle in hot water. Encourage idea exchange.
- Get 3 cups of hot water. Put it in a bowl and put the bottle in the bowl also. Let each student feel the bottle as it warms up. Have them observe the balloon.
- Ask students if they think the balloon will change if we move the bottle to cold water. Encourage idea exchange.
- Get 2 cups of cold water and 4-6 ice cubes to put in the other bowl. Put the bottle in the bowl, and again let the students feel the bottle as it cools off. Have them observe the balloon.
- Let the students move the bottle back and forth as time allows, and encourage predicting what will happen when they do.
- Ask for possible explanations and accept them all as something to consider.

### 3. Whole class activity

- Put a string circle on the floor, in the middle of an open area (This should be large enough for all students to stand in without crowding.)
- Have the whole class stand up and explain that they are now going to "become" molecules. Explain that warm molecules are very active and spread out away from other molecules. Have them spread out and "bounce." Explain that molecules which bounce all over are a gas.
- Ask if they've ever seen children "huddle" on the playground on a very cold day. Molecules do the same thing. They slow down and move closer together when they are cold. Ask the students to come into the circle and to huddle close together. They should then "freeze". When molecules get cold enough they freeze, although that does not mean they are totally without motion, even as the children will not be totally without motion. Ask if they can think of an example of something "frozen" (ice). Explain that this is a solid.
- Molecules are sometimes in between. We call this state liquid. They spread out a little bit, but they stay inside their container. Have the students bounce slightly and push apart but stay inside the circle. Ask for an example of a liquid (water).
- Have them get back in their huddle, very still and "cold." Then have them "warm up" gradually, staying in the circle. Then have them warm up more, and explain that they can now float up over the string because they are a "gas." Ask what would happen if they were even "hotter" (they would spread out even more).
- Now you are ready for some exercise. Using the cues Hot, Warm, Cold, etc, or Solid, Liquid, Gas, have them show by their actions what the molecules would do in that state.

### 4. Discussion

- Now discuss the experiment from earlier in the lesson. Ask for ideas on what the molecules were doing inside the balloon.

### TYING IT ALL TOGETHER

This provides a good basis of understanding for further studies of matter. Part/whole relationships in many areas can be related back to this. Students could be asked to begin a chart of solids, liquids, and gases using words or pictures.

---

[Click here](#) to return to OFCN's Academy Curricular Exchange

[Click here](#) to return to OFCN's Academy

[Click here](#) to return to OFCN's Main Menu

---

*[John Kurilecjmkn@ofcn.org](mailto:John.Kurilecjmkn@ofcn.org)*



6

**Academy Curricular Exchange  
Columbia Education Center  
Science**

---

**TITLE:** WATER MAGIC

**AUTHOR:** Cindy Miller, Precott High School, Prescott, AZ

**GRADE LEVEL/SUBJECT:** K to 4, Science, Arithmetic, Language, Health; Analysis, Comparing, Similarities and Differences, Drawings, Evaluation, Experimenting, Observation

**OVERVIEW:** This activity will introduce new vocabulary and will serve as a building block to future lessons on the water cycle. Students will use experiences from their everyday lives to practice the above skills.

**PURPOSE:** This activity is designed to help students understand that water picks up natural and man-made substances as it moves over and through the earth. Students will observe and experiment with water in three physical forms.

**OBJECTIVES:** Participants will be able to:

- 1) observe water in different physical forms
- 2) theorize what happens in the evaporation process, and
- 3) observe residues left after water evaporates.

**RESOURCES/MATERIALS:** Refrigerator, small plastic glasses or a jar, water source, rulers, balance scale, tea kettle, hot plate and mirror.

**ACTIVITIES AND PROCEDURES:**

1. Show the student an ice cube, or provide each student with an ice cube in a cup.
2. Ask the students what the cube is made of and ask them to put them in the glass and observe what happens.
3. When the ice has melted, discuss the difference between the solid form of water and the liquid form.
4. Have the students leave their glasses of water on a shelf and ask them what they think might happen.
5. When the water has evaporated, discuss with them what has happened and compare this to their answers to what they thought would happen in step 4.
6. Observe the sides and bottom of the glasses and, if necessary, compare them to a new glass.
7. Discuss with them where the film came from that is left on the sides and bottom of the glass.
8. Heat water in the tea kettle and, when boiling, hold the mirror over the opening in the spout and observe what happens.
9. Discuss with them how water becomes steam and is able to move into the air.

**TYING IT ALL TOGETHER:** Have the students draw the things that they observed. Have student describe the three physical forms of water and compare and contrast them. Test students knowledge of the following vocabulary words: Solid, Liquid, Gas, Vapor, Absorb, Evaporation.

[Click here](#) to return to OFCN's Academy Curricular Exchange

[Click here](#) to return to OFCN's Academy

[Click here](#) to return to OFCN's Main Menu

---

*John Kurilec* [jmk@ofcn.org](mailto:jmk@ofcn.org)

7

**Academy Curricular Exchange  
Columbia Education Center  
Science**

---

**TITLE:** DIFFUSION OF MOLECULES

**AUTHOR:** Margaret Sorensen, Holy Rosary Elementary  
School; Idaho Falls, Idaho

**GRADE LEVEL/SUBJECT:** Third/Fourth Grade Chemistry

**OVERVIEW/PURPOSE:**

1. Molecules in a liquid move.
2. Molecules do not move in any specific direction in a liquid.
3. A solution is a liquid mixture of two or more substances in which the substances are completely mixed.
4. Heat will increase and cold will decrease the speed of molecular movement in water.
5. Stirring will increase the speed of molecular movement and the speed with which substances will dissolve.
6. Rubbing alcohol and soap makes molecules move faster in water.

**OBJECTIVES:**

1. To understand molecular movement
2. To develop skills in performing a chemistry investigation.
3. To develop skills in making hypotheses.
4. To develop observational skills.
5. To develop creativity and imagination in modifying science investigation.

**RESOURCES/MATERIALS:**

food coloring, watch, water, eyedroppers, warm water, rubbing alcohol, dish soap, ice cubes, plastic cups, small plastic bags

**VOCABULARY:** dissolve, diffusion, molecules

**ACTIVITIES AND PROCEDURES:**

1. This activity can be done with an entire class, as a learning center group activity or as an individual project. Do not go over the concepts at this point. This is a discovery activity in which the children figure out the concepts from the results of the investigation.
2. Distribute the materials to the students. Each will need a clear plastic cup of water and an eyedropper holding some food coloring for the part of the experiment. While most of the students are working on this activity, have your student helpers pass out small plastic cups of warm or hot water. The alcohol, the dish soap and the food coloring may be distributed in containers to be shared. Any colors of food coloring will work, but red and blue are the easiest colors to

- see as they dissolve.
3. Encourage your fast-finishing students to do each investigation a second time, comparing the speeds and keeping a record of the results. Children should know that experiments are checked many times by real scientists.
  4. Place a drop of food coloring in a cup of water. How many seconds did it take to completely dissolve in the water?
  5. Place one or two ice cubes in the cup of water. Place a drop of food coloring on an ice cube. What happened?
  6. Place a drop of food coloring in the cold water. How many second did it take for the food coloring to completely dissolve in the cold water.
  7. Place a drop of food coloring in a cup of water. Add a few drops of alcohol. How did the alcohol affect the solution?
  8. Add a drop of food coloring to a cup of warm water. How many seconds did it take for the coloring to dissolve completely in the warm water.
  9. Add another drop of food coloring to the water. Then add a few drops of dish soap to the water. What happened?

**TYING IT ALL TOGETHER:**

This activity integrates well with art. Your students can use markers, colored pencils, crayons or watercolors to draw their own versions of the designs produces in the cups by the dissolving food coloring. This makes a very colorful bulletin board display, especially if the construction paper the children are is drawing on is cut into the shape of large cups.

---

[Click here](#) to return to OFCN's Academy Curricular Exchange

[Click here](#) to return to OFCN's Academy

[Click here](#) to return to OFCN's Main Menu

---

*John Kurilecjm@ofcn.org*

BEST COPY AVAILABLE

**Academy Curricular Exchange  
Columbia Education Center  
Science**

---

**TITLE:** MOLECULES and TEMPERATURE

**AUTHOR:** Kathy D. Baim, Holy Rosary Elementary,  
Idaho Falls, Idaho

**GRADE LEVEL:** Appropriate for Primary Grades

**OVERVIEW and PURPOSE:** The study of molecular concepts, especially their movement and relationship to temperature, is difficult for primary children to grasp. Through language arts, science experiment and movement activity, students will gain an understanding of temperature and molecular movement.

**OBJECTIVES:** Students will be able to:

1. Explain that molecules are in everything living and nonliving.
2. Explain that molecules are too small to see but we can watch their movement.
3. Demonstrate molecular movement in hot and cold water and explain temperature rise and fall depending on molecular movement.
4. Through oral and written expression demonstrate an understanding of the following vocabulary words: temperature, molecule, movement, molecular movement, particle, rise and fall.
5. Through movement activity, demonstrate molecular movement as pertaining to rising and falling temperature.

**RESOURCES/MATERIALS NEEDED:**

Hot as an Ice Cube by Philip Balestrino  
Two clear cups/bowls and food coloring  
Observation page (see below)

**ACTIVITIES AND PROCEDURES:**

- A. Read Hot as an Ice Cube by Philip Balestrino  
Concepts to develop:
  1. Temperature is a measure of how hot or cold something is.
  2. Adjectives to describe temperature such as hot, cold, warm, lukewarm, chilly, sizzling and freezing.
  3. Heating something makes its temperature rise. As it cools off its temperature falls.
  4. Everything is made of tiny particles called molecules.
  5. Molecules are always moving.
  6. The faster the molecules in something move, the hotter it is. The more you heat something, the faster the molecules move. This is what causes its temperature to rise.
- B. Experiment-To see that molecules of water move faster when the water is hot.

**BEST COPY AVAILABLE**

3/1/99 6:55 PM

1. Put water in two clear cups/bowls (one hot, one cold).
2. Allow the water to sit for a moment to stop movement.
3. Carefully put a drop of food coloring into the middle of each cup.
4. Observe the molecules move the food coloring around (rapidly in hot water, slowly in cold water).

C. Observation page:

Name: \_\_\_\_\_ Date: \_\_\_\_\_

Material: \_\_\_\_\_

Procedure (What I did): \_\_\_\_\_

A picture of what I saw:

Here are things I noticed:

---

TYING IT ALL TOGETHER:

Extension Activity: Small groups of children act out being molecules. They start out as frozen water (clustered very still as frozen water molecules). Pretend the temperature is gradually rising until it reaches boiling (children move around rapidly) and then let the temperature fall again.

---

[Click here](#) to return to OFCN's Academy Curricular Exchange

[Click here](#) to return to OFCN's Academy

[Click here](#) to return to OFCN's Main Menu

---

*[John.Kurilecjm@ofcn.org](mailto:John.Kurilecjm@ofcn.org)*

**Academy Curricular Exchange  
Columbia Education Center  
Science**

---

**TITLE:** SUPERBALLS

**AUTHOR:** Agnes Simon  
Greenfield School, Gilbert, AZ 85234

**GRADE LEVEL / SUBJECT:** 4-6, Science

**OVERVIEW:** The students will mix two different solutions and arrive at surprising results. The reaction - is it chemical or physical? - will help child understand molecules and polymers.

**OBJECTIVES:** The students will be able to:

1. Demonstrate their ability to follow directions.
2. Understand and be able to explain the reaction and polymers.
3. Show an enjoyment and appreciation for Science.

**MATERIALS:**

25 ml Elmer's glue-all  
5 ml sodium borate solution \*\*  
20 ml water (tap water is fine)  
1-5 drops food coloring (optional)  
popsicle stick or stirring rod  
plastic wrap  
plastic bag  
plastic cup  
measuring spoons  
graduated cylinder 50 ml  
5 oz. paper cup  
\*\* To make the sodium borate solution, mix 4 grams of sodium borate ( $\text{Na}_2\text{B}_4\text{O}_{10}$ ) or borax in water to make 100 ml of solution. Be sure it is dissolved.)

**ACTIVITIES AND PROCEDURES;**

**Activity:**

**Time:** Prepare ahead of time the sodium borate solution.  
20-30 minutes to perform the activity.

**Procedure:**

1. Fill a paper cup with about one-inch of Elmer's glue. This should be about 25 ml. (Using a graduated cylinder to measure out the glue is not recommended due to the clean up involved.)
2. Using a graduated cylinder, measure out 20 ml of water and add it to the cup of glue. Stir well.
3. Add 1-5 drops of food coloring is desired and stir well.
4. Using a graduated cylinder, measure out 5 ml of sodium borate solution. Add it to the glue mixture and stir will.
5. Remove the solid material from the cup and place it on a piece of plastic wrap.
6. Pull the solid off the stirring rod or popsicle

stick, and let the material sit for a minute or two. The solid will be sticky for the first couple of minutes.

7. Putty is now ready to knead, roll, stretch, etc.
8. Answer the following questions regarding the physical properties of the Sill Putty-type material:
  - a. Does it stretch?
  - b. What happens when it is pulled hard?
  - c. Roll a piece into a ball and drop it on a hard surface. Does it bounce?
  - d. Roll a piece into a ball and let it sit on a flat surface undisturbed. What do you observe?
9. For additional fun, take two different colored balls of material and place one on top of the other. Observe. Can you completely separate the two?
10. Store the Silly Putty-type material in a closed plastic bag.
11. Wash hands and materials completely when finished.

TYING IT ALL TOGETHER: This activity can be an introductory activity or used as part of a series of lessons on polymers and molecules. Activities that can be used before or after this lesson are the Rubber Band, Needle Through a Balloon, and Glop (made with cornstarch and water.)

---

[Click here to return to OFCN's Academy Curricular Exchange](#)

[Click here to return to OFCN's Academy](#)

[Click here to return to OFCN's Main Menu](#)

---

[John.Kurilec@ofcn.org](mailto:John.Kurilec@ofcn.org)



**Academy Curricular Exchange  
Columbia Education Center  
Science**

---

Dorothy Manning, Edgemont Elementary, Idaho Falls, ID

**THE MOTION OF MOLECULES IN WATER**

Appropriate for grades 4-7.

**OVERVIEW:** The concepts involved with atomic theory are difficult for teachers to demonstrate because the particles involved are too small to actually see and manipulate. Whenever possible it is helpful to allow students to observe actual concepts and then either develop their own theories about what was seen, or reconcile what they have seen with what they have been taught happens.

**PURPOSE:** The purpose of this activity is to assist students to visualize and better understand the concept of the constant motion of molecules.

**OBJECTIVES:** Students will be able to:

1. Observe the motion of water molecules using food coloring.
2. Compare dispersal time in hot, cold and room temperature water.
3. Record observation data on record sheets.

**ACTIVITIES:** Fill the beaker or jar  $\frac{3}{4}$  full of water. The students should be able to see the water level and that it is clear. Place the beaker where it can be seen by the students but will not be disturbed with any type of motion. Carefully place a few drops of food coloring on the surface of the water. Do not agitate or stir the color into the water. Allow the beaker or jar to sit and observe it periodically during the lesson. The color will disburse throughout the water. Depth of color will depend upon time allowed and how much food color was used.

To determine whether the temperature of the water has an effect, do the activity again using hot water and using the coldest water possible to obtain without freezing the water. Record the time it takes for the color to disburse throughout the water.

**RESOURCES/MATERIALS NEEDED:**

A clear glass jar or beaker (large enough to be easily seen by students), Water, Food coloring (a dark color such as green or blue is more easily seen).

Because of the time involved in allowing the food color to mix, student need to either be working on a related lesson which can be stopped periodically at the instructor's direction to refer to the activity, or students should be recording the activity on experiment record sheets.

TYING IT ALL TOGETHER:

1. Have the students illustrate the activity using a series of pictures. Students could illustrate the activity from the perspective of an individual molecule, or as a record of what the student observed happening at certain time intervals.

2. Students could write a summary on the activity describing what they observed happening. The summary could be factual and scientific, or could be in short story form as told by a molecule of water or a molecule of food coloring. bit intimidated by the stars if they have no prior experience.

---

[Click here](#) to return to OFCN's Academy Curricular Exchange

[Click here](#) to return to OFCN's Academy

[Click here](#) to return to OFCN's Main Menu

---

*[John Kurilecjm@ofcn.org](mailto:John.Kurilecjm@ofcn.org)*

### Related Books and References

Adoff, Arnold; Pinkney, Jerry ill. *In for Winter, Out for Spring*. San Diego: Harcourt Brace Jovanovich, 1990.

Balestrino, Philip. *Hot as an Ice Cube*.

Davis, Hubert J., Wallner, John C. *A January Fog Will Freeze a Hog*. New York: Crown Publishers, 1972.

Dorros, Arthur. *Follow the Water from Brook to Ocean*. New York: Harper Collins, 1991.

Moore, Elaine, Andreasen, Dan. *Grandma's Garden*. New York: Lothrop, Lee & Shepard Books, 1994.

Nelson, Betty Palmer. *Changing Seasons*. New York: St Martin's Press, 1996.

Zoehfeld, Kathleen Weidner. *What Is the World Made Of*. New York: Harper Collins, 1998.

**WATER DANCE**  
BY THOMAS LOCKER

New York: Harcourt Brace & Company, 1997

Jenny Cos  
Teaching Science through Children's Literature  
Dr. Malcolm Butler  
March 22, 1999

## Water Dance by Thomas Locker

### Summary

This beautifully illustrated book describes the many forms water takes and how water moves through our world. The water cycle is explored as we see and hear of water's journey between the earth and the sky.

### Science and Content Related Concepts

The water cycle and the three states of matter, erosion, gravity, tidal activity, weather, reflection/refraction, rainbows, and language arts development.

### TEKS

K.1, K.2, K.3, K.4, K.5, K.7, K.9, K.10  
1.1, 1.2, 1.3, 1.4, 1.5, 1.7, 1.9, 1.10  
2.1, 2.2, 2.3, 2.4, 2.5, 2.7, 2.9, 2.10  
3.1, 3.2, 3.3, 3.4, 3.5, 3.6, 3.7, 3.8, 3.11  
4.1, 4.2, 4.3, 4.4, 4.6, 4.7, 4.10, 4.11  
5.1, 5.2, 5.3, 5.4, 5.5, 5.6, 5.7, 5.8, 5.11, 5.12

## WATER FACTS

"What expands as it gets colder, holds more heat than a metal, can carry things heavier than itself, and can move upward against the force of gravity?" WATER!!! (Earth Science Book-Dinah Zike,p.60)

"Meteorologists, oceanographers, biologists, zoologists, botanists, ecologists, and geologists are just a few of the scientists who study hydrology, or how water is involved in Earth's processes."

(Earth Science Book-Dinah Zike, p.55)

\*All living things need water in order to survive.

\*Water makes up more than half of the body tissue of all plants and animals.

\*Nearly 80% of the Earth's surface is water.

\*97% of all water on Earth is saltwater

\*2% of all water on Earth is glacier ice at the North and South Poles

\*1% of all water on Earth is fresh drinking water

\*The amount of water on Earth today remains exactly the same as it was billions of years ago. It just "recycles".

\*American Water Works Association  
Denver,CO

## ACTIVITIES

### 1) Water Words

On a large piece of poster board or chart paper draw a huge droplet of water. Ask children to close their eyes and think about water. Ask them to raise their hands when they have thought of a word that describes water or a way we use water or a form of water or a sound that water makes. Fill up the water droplet with the words they have brainstormed and then read over the entire selection with the class. This activity could be extended by creating word trees of related words.

### 2) Rainmakers

Create the water cycle in your classroom. Ask children to bring in 2 identical glass or plastic jars(wider/stouter jars work best). Either have the children collect enough large stones for the whole class on the playground or a class walk, or have a supply available. Working with 2-3 students at a time, ask each student to select one stone and place it in one of their jars. Then fill the jar with water covering half the stone. Place the second jar upside-down on the first jar and duct tape them together. Put the finished jars in a sunny window or outside where they will get direct sunlight. Depending on the weather, the jars should start producing "rain" in a few short hours.

Activity found in Water Wizards, Massachusetts Water Resources Authority, Boston, MA, p. 4.

### 3) Water Molecules in Motion

This is a good experiment to show that molecules are moving all the time. Take a clear glass container and fill it with water. Let it stand until the water is still. Then drop just one(1) drop of blue food coloring into the jar and sit back and observe. Little by little the blue will spread throughout the jar as the molecules in the blue drop are pushed and pulled in every direction by the other water molecules in the jar. Heat keeps the molecules moving. It is interesting to try this experiment with hot or cold water - does the blue droplet react differently?

Activity found in A Drop of Water by Walter Wick, New York: Scholastic Press, 1997, p.18.

#### 4) Evaporation Plus

This activity helps children understand that water does indeed leave its liquid form and move into its gaseous state(into the air) as it evaporates. It can be measured dramatically over a period of days and weeks until the liquid has disappeared.

Begin this activity by discussing evaporation in our everyday lives. When we wash our hair, it dries after a few hours. If we hang a wet towel or shirt outside in the sun, it dries. Ask the children for other examples of evaporation or "water drying." Fill a clear container with water and make a line with permanent marker indicating the water level. Transfer this information to a graph using cubes or a ruler to measure the water level. Measure the water level every day and record the data on the graph. Watch it drop!

Discuss other variations of this experiment and try them out such as:  
-does the height or diameter of the container effect the rate of evaporation?

-does the location of the container make a difference... outside vs. inside, sun vs. shade, heat vs. cool?

-does wind play a role in rate of evaporation?

-What can you do to prevent evaporation?

Activity found in More Mudpies to Magnets by E. Sherwood, R. Williams, and R. Rockwell, Mount Rainier, MD: Gryphon House, 1990, p.109.

#### 5) Let's Dew It

" When warm air comes into contact with cool surfaces on the ground or on a cold object such as a glass, it becomes cooled to its "dew" point. When this happens, we see moisture form on the surface of the glass or on the blades of grass. This is surface condensation, and is called dew." - More Mudpies to Magnets, p.108

Many of the world's habitats rely on dew production as a critical water source particularly desert ecosystems. Some plants have even developed special adaptations to catch dew and store it. This activity provides a quick graphic example of how dew or condensation is formed. Ask children if they have ever walked on their lawns in the morning and gotten their feet wet. How did that water get there? Let them brainstorm possible explanations. Then



explain how the water has come from the air. Tiny water molecules in the air (a gas) form water we can see (a liquid) when they touch the cool ground and grass.

Place a glass on a table where the children can see it. Ask each child to place an ice cube in the glass. Then fill the glass with water. Ask the children what they think will happen. Water should condense on the outside of the glass in a very short time. How did the water get there? Was it spilled? Did it leak? Explain that the ice in the glass made the glass cold. When the warm air touched the cool glass, the water molecules in the air joined together and clung onto the cool surface. This is called condensation. Fill a jar with warm water. What happens? Place a cold piece of metal in the freezer. Put it out into humid air. What happens?

Activity found in More Mudpies to Magnets, p.108.

## 6) 100 Cups of Water

This activity helps children understand why the freshwater on Earth is such a valuable resource and why we need to take better care of it. Fill 100 cups with water to represent all the water on Earth. Put a drop of food coloring in 97 of the cups. These cups represent the 97% of Earth's water that is saltwater and undrinkable. Put ice cubes in 2 of the cups to represent the 2% of water on Earth that is glacial. And finally hold up the remaining 1 cup of water that represents the 1% of water on Earth that is freshwater and drinkable. The entire Earth drinks out of this one cup of fresh water.

This leads easily into a discussion about pollution and conservation.

Activity found in The Earth Science Book by Dinah Zike, p.57.

## 7) The Waterworks

Ask children where they think the water in their homes comes from. Record their explanations. Then read The Magic School Bus at the Waterworks by Joanna Cole. Then review the process -- lakes/rivers/oceans, sun, clouds, precipitation, streams, lake, reservoir, water purification system, filters, chlorine, fluoride, water main, pipes, and water pressure. Then act out or build this system with props. Try to have enough props for each child to participate.

Blue fabric and ribbons for bodies of water and reservoir, yellow ball or picture of sun, cotton batting for clouds, strings of laminated raindrops, box for water treatment plant, funnel or jar of gravel and sand for filter, empty detergent bottle for chlorine, toothbrush for flouride, wrapping paper tubes for water mains, papertowel tubes and straws for pipes, and different sizes of boxes for houses and buildings. A good field trip after this lesson and activity is a trip to your local water treatment plant.(Corpus Christi Water Dept., contact Yolanda Marruffo at 857-1879).

## 8) Cleaning Muddy Water

How can water be cleaned? By using a filter made from natural materials found outside and some recyclable items from inside your house. Talk about the function of a filter- how it works. Have a jar of dirty water available to examine and elicit suggestions.

To make a filter: Cut the top third of a liter soda bottle off and remove the cap. Place it upside down resting on top of a clear container. Place a rock in the neck of the bottle so that it plugs most of the hole. Next add a layer of crushed rock. Then add a layer of sand. Shake the jar of dirty water to loosen the sediment from the bottom and pour it into the filter. Watch as clear water fills the container. If there is still significant dirt in the water, filter it through again. The water will not be completely clean because it still contains bacteria and microscopic organisms. Iodine tablets will purify it for drinking. A more interesting extension of this activity however would be to evaporate the filtered water or filter through a white coffee filter to see what might still be left in the water.

Activity found in More Mudpies to Magnets, p.95.

## 9) How much water do we use?

This activity provides a great way to dramatically see our individual water use and to share it with our school community. A week or two before this lesson, ask children to bring in empty WASHED plastic gallon milk jugs. You will need 60 milk/water jugs. Don't tell them what they are for. Begin the lesson by holding up a single gallon jug. Ask children to estimate how many jugs of water they use a day. Record these estimates. Show them the collection of gallon jugs. Then explain that the average person uses 60 gallons of water a day

at home: 45% for toilet flushing, 30% for bathing, 15% for cooking/dishes/laundry, and 10% for outdoor uses.

Depending on what your students have covered in math, you can have them figure out how many gallons for each percentage. Other wise tell them 27 gal. for toilet flushing, 18 gal. for bathing, 9 gal. for dishes/cooking/laundry, and finally 6 gal. for outdoors. Have them arrange the gallon jugs according to use out in the hallway and create a display explaining our water use. Conservation measures can be added to this display later to further educate the school community.

Activity found in Water Wizards, p. 19.

## 10) Water Conservation

Throughout this water unit, the children have learned about where water comes from, the water cycle, how to clean water, how water gets to our houses and schools, how much water we use, and what a valuable and limited resource freshwater is. It is now important to discuss that given the above, we must all participate in protecting and conserving this natural resource that all living plants and animals need. Human beings are the only living things that pollute and therefore we must take the responsibility of keeping our Earth's water clean. This is especially true in more populated areas. It is expensive to find new water sources. An example would be the new pipeline Corpus Christi had to build in order to increase its water supply. Conservation methods go a long way in helping decrease our water needs. If everyone uses less water, than we reduce the need for continued searching for new water sources.

We as individuals can make a difference. By changing our water use habits we can save water. See attached Family Water Conservation checklist for specific ways to save water in our daily activities. Encourage students to share this information with their families. You could even plan a Family Water Night for the students to share all that they have learned about water over the past few weeks.

Children could also design and hang up posters and signs in the school bathrooms to remind the school community to conserve water.

Information from Water Wizards, pp. 22-25.

## Bibliography

- Brenner, Barbara(Ed), The Earth is Painted Green, New York: Scholastic,1994.
- Burnie, David, 101 Nature Experiments, New York: Dorling Kindersley, 1996.
- Cole, Joanna, The Magic School Bus at the Waterworks, New York: Scholastic, 1986.
- Locker, Thomas, Water Dance, New York: Harcourt Brace & Co., 1997.
- Schenk de Regniers, Beatrice, Eva Moore, Mary Michaels White and Jan Carr(Eds), Sing a Song of Popcorn, New York: Scholastic, 1988.
- Serfozo, Mary, Rain Talk, New York: Scholastic, 1990.
- Sheehan, Kathryn and Mary Waidner, EARTH CHILD, Tulsa, OK: Council Oak Books, 1991.
- Sherwood, Elizabeth, Robert Williams, and Robert Rockwell, More Mudpies to Magnets, Mt. Rainier, MD: Gryphon House, 1990.
- Spier, Peter, RAIN, New York: Doubleday, 1982.
- The Story of Drinking Water*, Denver, CO: American Water Works Association, Catalog No. 70001.
- Stryker, Sandy and Mindy Bingham, Mother Nature Nursery Rhymes, Santa Barbara, CA: Advocacy Press,1990.
- Tresselt, Alvin, RAIN DROP SPLASH, New York: Scholastic, 1946.
- Water Wizards*, Boston, MA: Massachusetts Water Resources Authority, circa 1988.
- Wick, Walter, A Drop of Water, New York: Scholastic, 1997.
- Williams, Vera, Three Days on a River in a Red Canoe, New York: Greenwillow Books, 1981.

Zike, Dinah, Big Book of Books and Activities, San Antonio, TX: Dinah-Might Activities, 1993.

Zike, Dinah, The Earth Science Book, New York: John Wiley & Sons, 1993.

# LIVING JOURNAL

Name \_\_\_\_\_

Each person, on the average, uses 60 gallons of water a day for bathing, toilet flushing, cooking (dishwashing), and outdoor use.

If there are 25 people (approximately the number of students in our class), using 60 gallons a day, how many gallons of water does the class use altogether every day.

How many in one week?

How many in one month?

How many in one year?

How many in one decade?

How many in one century?

Calculate: \* Remember how to multiply with a zero.

~~Example~~  $25 \times 60 = \square$

$25 \times 6 = \square$

$25 + 25 + 25 + 25 + 25 + 25 = \square$

Then add a zero .



## FAMILY WATER CONSERVATION CHECKLIST

**TOILET:** People use more water flushing the toilet than any other way.

- Don't use the toilet as a wastebasket.
- Save water on each flush by displacing the water in the tank with a quart-size plastic bottle filled with water.
- Use a toilet tank dam to hold back some water on each flush.
- Check for leaks and repair any that you find.
- Flush only when there is solid waste in the toilet bowl.

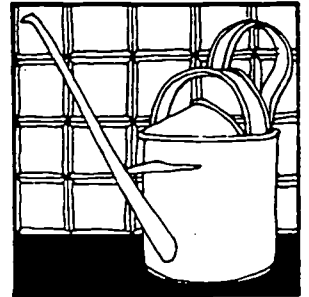

**BATH AND SHOWER:** Water and energy can be wasted, since energy is used to heat the water.

- Turn off the shower while soaping up. There are on/off switches (available from plumbing supply stores) to help you do this.
- Take showers instead of baths.
- Take shorter showers.
- Install a water-saving showerhead.
- Fill the tub only part way when bathing.
- Recycle bath water by using it on house plants.

**SINK:** Don't let water run down the drain while you do the following:

- Brush your teeth.
- Shave.
- Wash and rinse dishes.
- Wait for water to get cold to have a drink. Instead, keep a container of drinking water in the refrigerator.
- Wash fruits or vegetables.

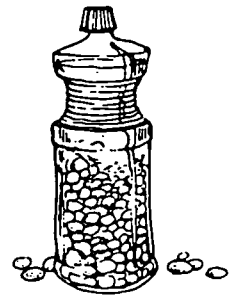

**APPLIANCES:**

- Wash only full loads of dishes or clothes, or use the low-volume setting if your machine has one.

**GENERAL HOUSEHOLD:**

- Do a home leak-check on all faucets and water lines to appliances. Repair any leaks that you find.

**OUTDOORS:**

- Water the garden and lawn at dusk, when the day is cool. This is better for plants, too.
- Mulch the garden to retain moisture in the soil.
- Wash the car with a bucket of suds. Use a hose only when rinsing, and always use a nozzle on the hose.
- Use "trickle" irrigation instead of sprinkling.
- Sweep walks and driveways, instead of hosing them.
- Do not water the concrete -- it doesn't grow.

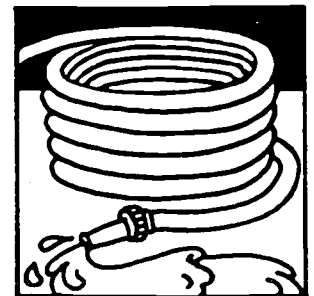

SOUND OF WATER

The sound of water is:

- Rain,
- Lap,
- Fold,
- Slap,
- Gurgle,
- Splash,
- Churn,
- Crash,
- Murmur,
- Pour,
- Ripple,
- Roar,
- Plunge,
- Drip,
- Spout,
- Skip,
- Sprinkle,
- Flow,
- Ice,
- Snow.



The rain is raining all around,  
 It falls on field and tree,  
 It rains on the umbrellas here,  
 And on the ships at sea.

Robert L. Stevenson

RAIN POEM

The rain was like a little mouse,  
 quiet, small and gray.  
 It pattered all around the house  
 and then it went away.

It did not come, I understand,  
 indoors at all, until  
 it found an open window and  
 left tracks across the sill.

ELIZABETH COATSWORTH

Mary O'Neill



RAIN

*Cinquaine  
 sty  
 2 pattern  
 4 syllables*

Some nights  
 you stay awake  
 gathering up the rain,  
 storing it in giant basins  
 until

they burst  
 and overflow,  
 flooding the sleeping earth.  
 Other times it is a surprise  
 when you

send down  
 bright, bouncing drops  
 that hurry along streets  
 to dry themselves in a gleaming  
 rainbow.

Myra Cohn Livingston  
SKY SONGS

BEST COPY AVAILABLE





# Rain

## RAIN SIZES

Rain comes in various sizes.  
Some rain is as small as a mist.  
It tickles your face with surprises,  
And tingles as if you'd been kissed.

Some rain is the size of a sprinkle  
And doesn't put out all the sun.  
You can see the drops sparkle and twinkle,  
And a rainbow comes out when it's done.

Some rain is as big as a nickle  
And comes with a crash and a hiss.  
It comes down too heavy to tickle.  
It's more like a splash than a kiss.

When it rains the right size and you're wrapped in  
Your rainclothes, it's fun out of doors.  
But run home before you get trapped in  
The big rain that rattles and roars.

John Ciardi  
The Reason for  
the Pelican

## SHOWERS

Marchette Chute

Squelch and squirt and squiggle  
Drizzle and drip and drain—  
Such a lot of water  
Comes down with the rain.

## I am the Rain

I am the rain  
I like to play games  
like sometimes I pretend  
I'm going to

fall  
Man that's the time  
I don't come at all

Like sometimes  
I get these laughing stitches  
up my sides  
rushing people in

and out  
with the clothesline

I just love

drip  
dropping  
down  
collars  
and spines

Maybe it's a shame  
but it's the only way  
I get some fame

Grace  
Nichols

## Waves of the Sea

Waves of the sea  
make the sound of thunder  
when they break against rocks  
and somersault under.

Waves of the sea  
make the sound of laughter  
when they run down the beach  
and birds run after.

Deep glass-green seas  
 chew rocks  
 with their green-glass jaws.  
 But little waves  
 creep in  
 and nibble softly at the sand

Lilith Norman

SLAVE OF THE MOON

The sea rushes up  
 To eat the muddy shore,  
 Slips back into the waves  
 To return once more.

Spluttering, foaming, frothing  
 Pulling at the land  
 Again it tries to eat  
 The dampened, salty sand.

But will it reach  
 Its destination soon?  
 Or must it always be  
 The slave of the moon?

Mary Yarmon  
 Age 11, Canada

Miracles (Poems  
 collected by Richard  
 Lewis)

BY THE SEA

The salty wind,  
 the sound of the sea,  
 the sand and the sun,  
 the waves and the spray—  
 a glistening, glittering  
 jewel of a day!

Charlotte Zolotow

RIVER WINDING by Charlotte Zolotow

Rain falling, what things do you grow?  
 Snow melting, where do you go?  
 Wind blowing, what trees do you know?  
 River winding, where do you flow?

There's big waves and little waves,  
 Green waves and blue,  
 Waves you can jump over,  
 Waves you dive through,  
 Waves that rise up  
 Like a great water wall,  
 Waves that swell softly  
 And don't break at all,  
 Waves that can whisper,  
 Waves that can roar,  
 And tiny waves that run at you  
 Running on the shore.

ELEANOR FARJEON

Surf



Waves want  
 to be wheels.  
 They jump for it  
 and fail  
 fall flat  
 like pole vaulters  
 and sprawl  
 arms outstretched  
 foam fingers  
 reaching.

Lillian Morrison

THE RIVER

Quiver shiver,  
 golden river,  
 how you hold the sun!

Shimmer glimmer,  
 little waves,  
 showing day is done.

Charlotte Zolotow

LONG TRIP

The sea is a wilderness of waves  
 A desert of water.  
 We dip and dive,  
 Rise and roll,  
 Hide and are hidden  
 On the sea.  
 Day, night,  
 Night, day,  
 The sea is a desert of waves,  
 A wilderness of water.

—Langston Hughes



**U.S. Department of Education**  
 Office of Educational Research and Improvement  
 (OERI)  
 National Library of Education (NLE)  
 Educational Resources Information Center (ERIC)



## Reproduction Release

(Specific Document)

### I. DOCUMENT IDENTIFICATION:

Title: <i>Children's Literature with a Science Emphasis: TEO Teacher-Developed K-8 Activity Packets</i>	
Author(s): <i>Malcolm B. Butler</i>	
Corporate Source:	Publication Date:

### II. REPRODUCTION RELEASE:

In order to disseminate as widely as possible timely and significant materials of interest to the educational community, documents announced in the monthly abstract journal of the ERIC system, Resources in Education (RIE), are usually made available to users in microfiche, reproduced paper copy, and electronic media, and sold through the ERIC Document Reproduction Service (EDRS). Credit is given to the source of each document, and, if reproduction release is granted, one of the following notices is affixed to the document.

If permission is granted to reproduce and disseminate the identified document, please CHECK ONE of the following three options and sign in the indicated space following.

The sample sticker shown below will be affixed to all Level 1 documents	The sample sticker shown below will be affixed to all Level 2A documents	The sample sticker shown below will be affixed to all Level 2B documents
PERMISSION TO REPRODUCE AND DISSEMINATE THIS MATERIAL HAS BEEN GRANTED BY  _____ _____ TO THE EDUCATIONAL RESOURCES INFORMATION CENTER (ERIC)	PERMISSION TO REPRODUCE AND DISSEMINATE THIS MATERIAL IN MICROFICHE, AND IN ELECTRONIC MEDIA FOR ERIC COLLECTION SUBSCRIBERS ONLY, HAS BEEN GRANTED BY  _____ _____ TO THE EDUCATIONAL RESOURCES INFORMATION CENTER (ERIC)	PERMISSION TO REPRODUCE AND DISSEMINATE THIS MATERIAL IN MICROFICHE ONLY HAS BEEN GRANTED BY  _____ _____ TO THE EDUCATIONAL RESOURCES INFORMATION CENTER (ERIC)
Level 1	Level 2A	Level 2B
Check here for Level 1 release, permitting reproduction and dissemination in microfiche or other ERIC archival media (e.g. electronic) and paper copy.	Check here for Level 2A release, permitting reproduction and dissemination in microfiche and in electronic media for ERIC archival collection subscribers only	Check here for Level 2B release, permitting reproduction and dissemination in microfiche only
Documents will be processed as indicated provided reproduction quality permits. If permission to reproduce is granted, but no box is checked, documents will be processed at Level 1.		

I hereby grant to the Educational Resources Information Center (ERIC) nonexclusive permission to reproduce and disseminate this document as indicated above. Reproduction from the ERIC microfiche, or electronic media by persons other than ERIC employees and its system contractors requires permission from the copyright holder. Exception is made for non-profit reproduction by libraries and other service agencies to satisfy information needs of educators in response to discrete inquiries.

Signature: <i>Malcolm B. Butler</i>	Printed Name/Position/Title: <i>Malcolm B. Butler, Program Specialist</i>	
Organization/Address: <i>Eisenhower Consortium @ SERVE 41 Marietta St. NW, Suite 1110 Atlanta, GA 30303</i>	Telephone: <i>404.893.0100</i>	Fax: <i>404.577.7812</i>
	E-mail Address: <i>mbutler@serve.org</i>	Date: <i>10.13.00</i>

### III. DOCUMENT AVAILABILITY INFORMATION (FROM NON-ERIC SOURCE):

If permission to reproduce is not granted to ERIC, or, if you wish ERIC to cite the availability of the document from another source, please provide the following information regarding the availability of the document. (ERIC will not announce a document unless it is publicly available, and a dependable source can be specified. Contributors should also be aware that ERIC selection criteria are significantly more stringent for documents that cannot be made available through EDRS.)

Publisher/Distributor:
Address:
Price:

### IV. REFERRAL OF ERIC TO COPYRIGHT/REPRODUCTION RIGHTS HOLDER:

If the right to grant this reproduction release is held by someone other than the addressee, please provide the appropriate name and address:

Name:
Address:

### V. WHERE TO SEND THIS FORM:

Send this form to the following ERIC Clearinghouse:
---

However, if solicited by the ERIC Facility, or if making an unsolicited contribution to ERIC, return this form (and the document being contributed) to:

**ERIC Processing and Reference Facility**

**4483-A Forbes Boulevard  
Lanham, Maryland 20706  
Telephone: 301-552-4200  
Toll Free: 800-799-3742  
e-mail: [ericfac@inet.ed.gov](mailto:ericfac@inet.ed.gov)  
WWW: <http://ericfac.piccard.csc.com>**

EFF-088 (Rev. 9/97)